

INTEROBIZ

www.interobiz.ro



Construction

Circulating pumps with a permanent magnet Synchronous motor.
Pump casing with suction and delivery connections with the same diameter and on the same axis (in-line).
Brass or cast iron unions on request.

Applications

For clean liquids, without abrasives, which are non-aggressive for the pump materials.
For heating plants.
For circulation plants.

Technical data

- Liquid temperature from +2 °C to +95 °C
- Ambient temperature from +2 °C to +40 °C
- Maximum permissible working pressure: 6 bar
- Storage: -20°C/+70°C max. relative humidity 95% at 40 °C
- Certifications: in conformity with CE requirements
- Sound pressure \leq 43 dB (A).
- Minimum suction pressure: 0,3 bar at 95 °C
- Maximum glycol quantity: 40%
- EMC according to: EN 55014-1,
EN 61000-3-2,
EN 55014-2
- Connections: threaded ports ISO 228: G 1 1/2, G 2

Motor

Synchronous motor with permanent magnet.

- Motor: 3000 rpm constant
- Standard voltage: single-phase 230 V (-10%;+6%)
- Frequency: 50 Hz
- Protection: IP 44
- Insulation class: H
- Class II appliance
- Overload protection (jammed rotor):
 - 1) automatic protection with electronic rotor release
 - 2) Overload thermal protector
- Cable : phases and neutral
- Constructed in accordance with: EN 60335-1, EN 60335-2-51

Characteristic curves, dimensions and weights

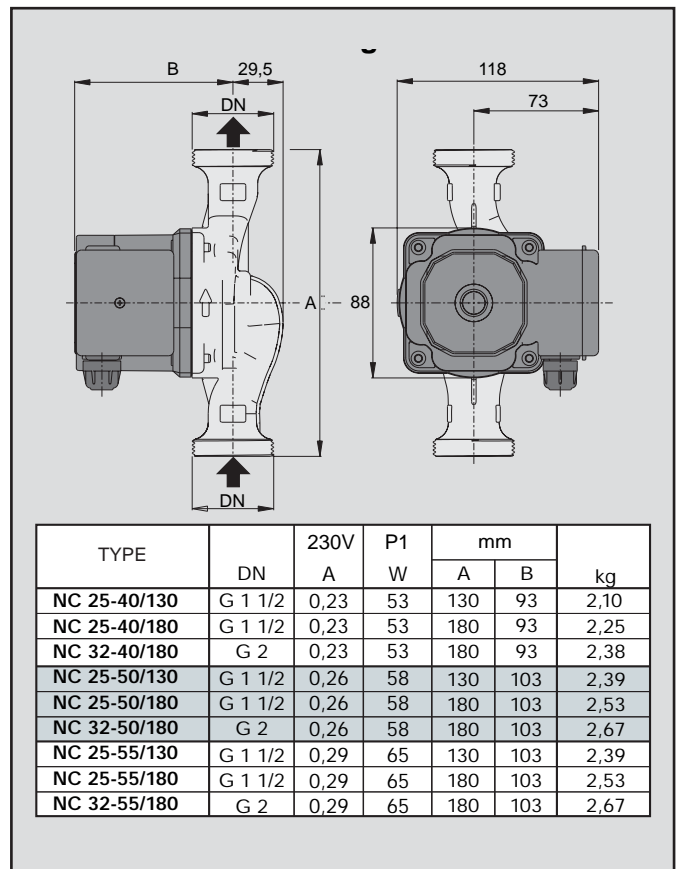
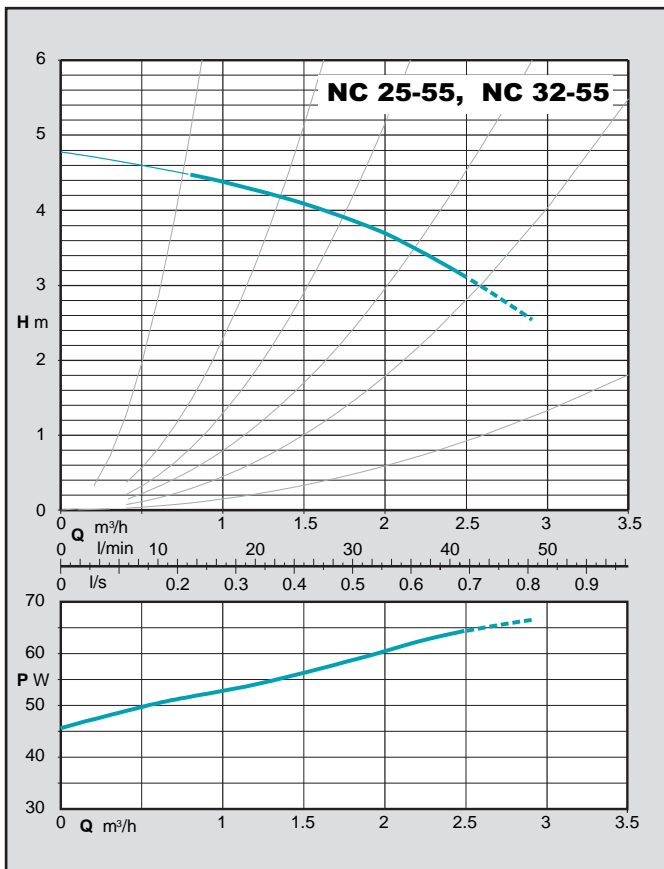
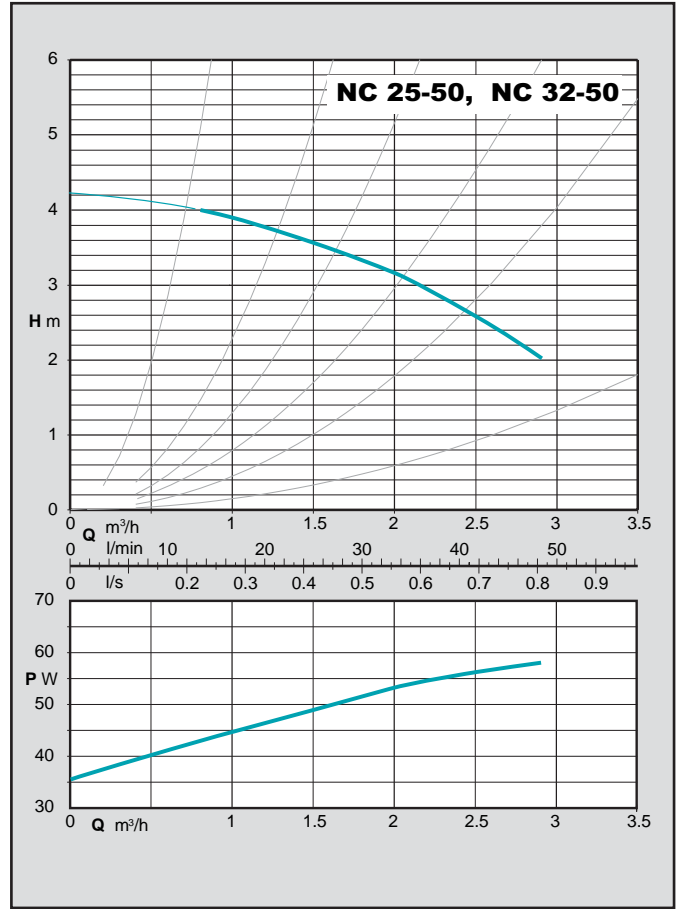
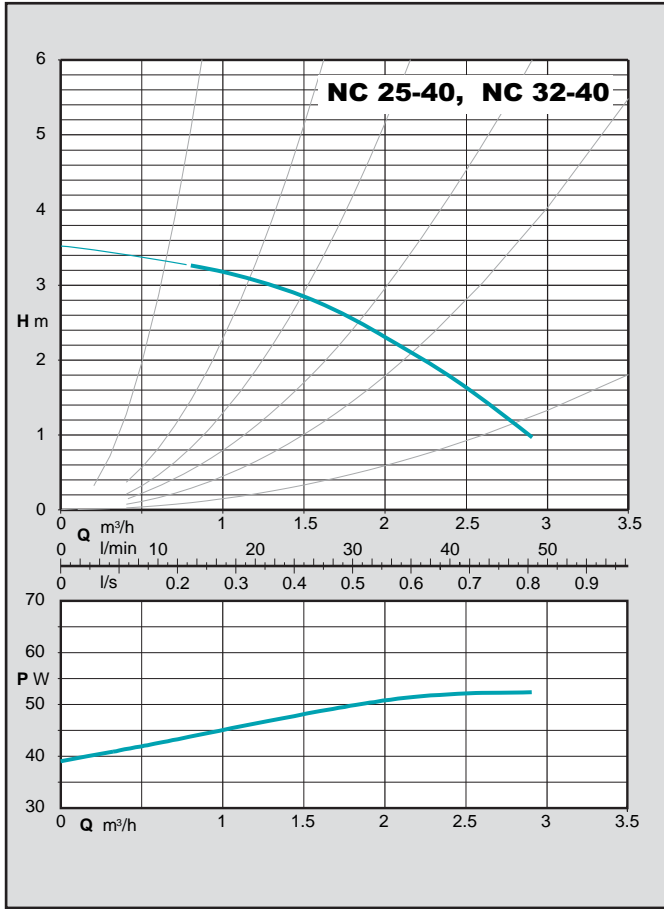

Materials

Component	Pos.	Material
Pump casing	1	Cast iron GJL 200 EN 1561
Impeller	2	Composite
Shaft	3	Stainless steel
Bearings	4	Spezialkohle
Thrust bearing	5	Ceramic
Rotor	6	Composite / Ferrite
Winding	7	Copper wire
Electronic card	8	-
Plug	9	Composite
Capacitor	10	-
Gasket	11	EPDM

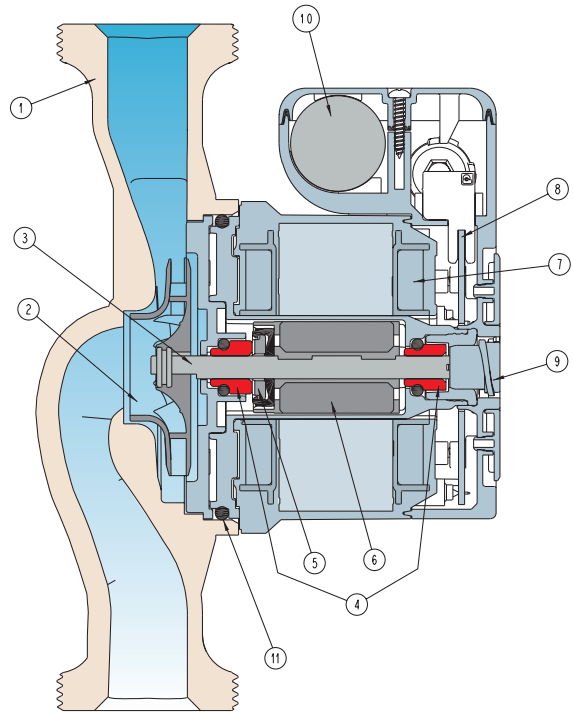

Installation

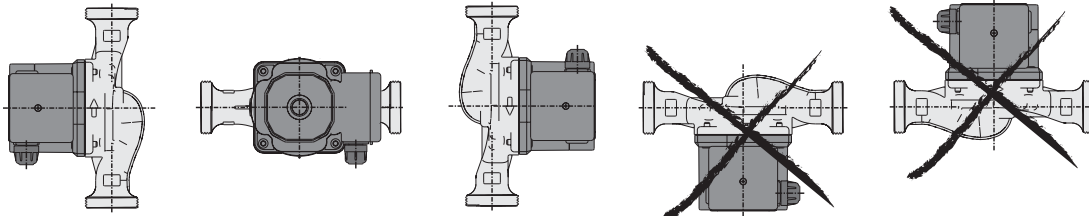

Terminal box arrangement

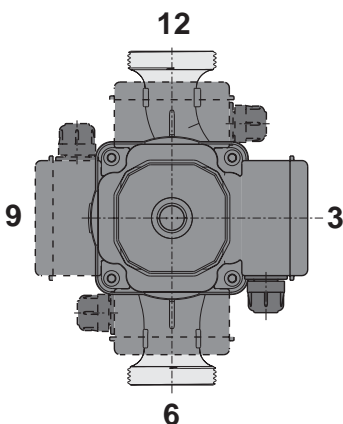

Unions

TYPE	DN	DN1
KIT G 1 - G 1/2 (NC. 15..)	G 1	G 1/2
KIT G 1 1/4 - G 3/4 (NC. 20..)	G 1 1/4	G 3/4
KIT G 1 1/2 - G 1 (NC. 25..)	G 1 1/2	G 1
KIT G 2 - G 1 1/4 (NC. 32..)	G 2	G 1 1/4

PERFORMANCE

The constant rotation speed of the synchronous motor allows for a reduction of the pressure variations under varying load losses. Moreover, the CALPEDA pumps are not affected by the temperature and the voltage mains. The traditional pumps can do it only by using sophisticated and expensive electronics.

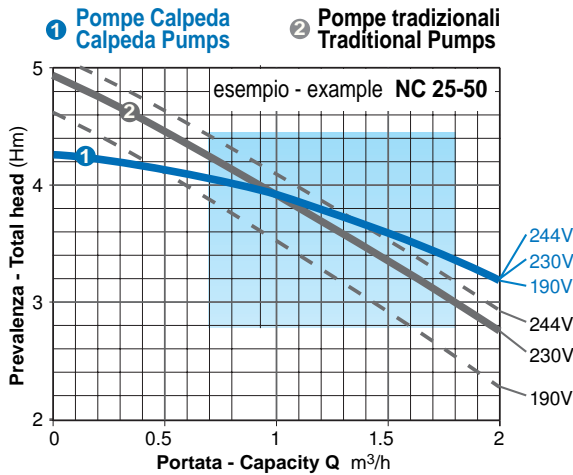

CONSUMPTION

Consumption cut out by over 40% With higher efficiency resulting in a lower absorbed current This means lower consumption, guaranteed savings.

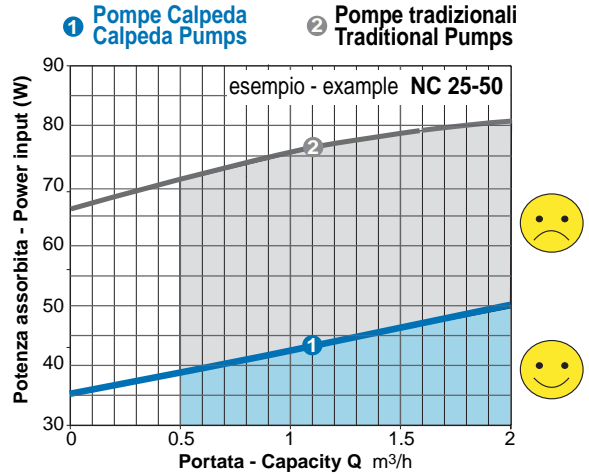

RELIABILITY

- The **patented** "squared chamber" eliminates any possibility of rotor stoppage.
- 1- The operational characteristics of the synchronous motor allow to larger gap between stator and rotor, compared to an asynchronous motor, without any reduction of efficiency.
 - 2- Being a permanent ceramic magnet, the rotor is less subject to limestone deposit than traditional metal rotors.
 - 3- The "intelligent" electronics can sense any rotation difficulties: in such circumstances the motor is turned over several times at a higher torque than in traditional motors.

Always guaranteeing proper starting.

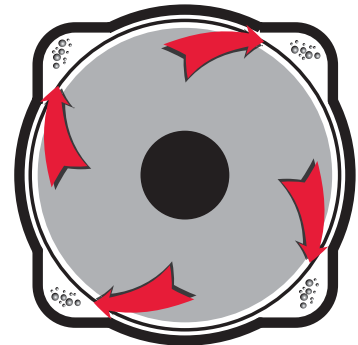

Patented

Escape routes for impurities inside the rotor chamber

SAFETY AND PRACTICALITY

Reliable electronics guarantee the perfect operation of the electropump with double electrical insulation Class II motor for greatest safety for users.

The reduced temperatures of the motor provide for the use of materials, which allow for an electropump with high electrical insulation, by eliminating the risk of dangerous electrical losses when compared to traditional pumps.

Interchangeability

The CALPEDA circulating pump has the same axis base of other traditional pumps.

QUALITY/PRICE

An extraordinarily advantageous quality/price ratio.



NC3

Three speeds circulating pumps with threaded ports



Construction

Pump casing with suction and delivery connections with the same diameter and on the same axis (in-line).
Brass or cast iron unions on request.

Materials	NC3 ..40-50-60	NC3 ...70-80-120
Pump casing	Cast iron	Cast iron
Impeller	Composite	Composite
Shaft	Stainless steel	Ceramic

Applications

For clean liquids, without abrasives, which are non-aggressive for the pump materials.
Civil and industrial heaty systems.

Operating conditions

Liquid temperature from +5 °C to +110 °C (from -10 °C to +110 °C for NC3 ...-70 and NC3 ...-80).
Ambient temperature up to 40 °C.
Sound pressure ≤ 43 dB (A).
Maximum glycol quantity: 50% (Mixture with more than 20% glycol content require rechecking of the pumping data).
Maximum permissible working pressure 10 bar.

type	Minimum suction pressure: bar		
	Temperature		
	50°C	80°C	110°C
NC3 ...-40,50,60	0,05	0,4	1,1
NC3 ...-70	0,05	0,4	1,1
NC3 ...-80,120	0,05	0,4	1,2

Motor

2-pole induction motor, 50 Hz.
Three adjustable speeds.
NC3: single-phase 230 V.
Insulation class H.
Protection IP 44.

Installation

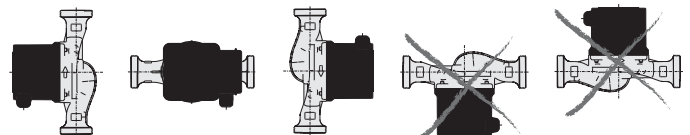

Unions

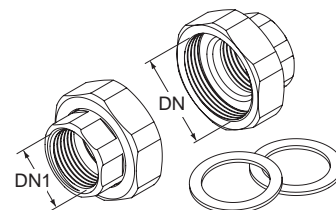

TYPE		DN	DN1
KIT G 1 - G 1/2 (NC. 15..)		G 1	G 1/2
KIT G 1 1/4 - G 3/4 (NC. 20..)		G 1 1/4	G 3/4
KIT G 1 1/2 - G 1 (NC. 25..)		G 1 1/2	G 1
KIT G 2 - G 1 1/4 (NC. 32..)		G 2	G 1 1/4

Designation

NC3 32 - 70 / 180

Series _____
DN ports in mm _____
Max. head in dm _____
connection size mm _____

Characteristic curves, dimensions and weights

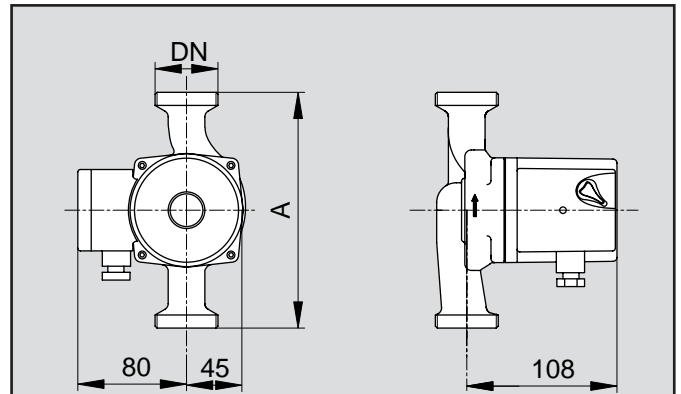
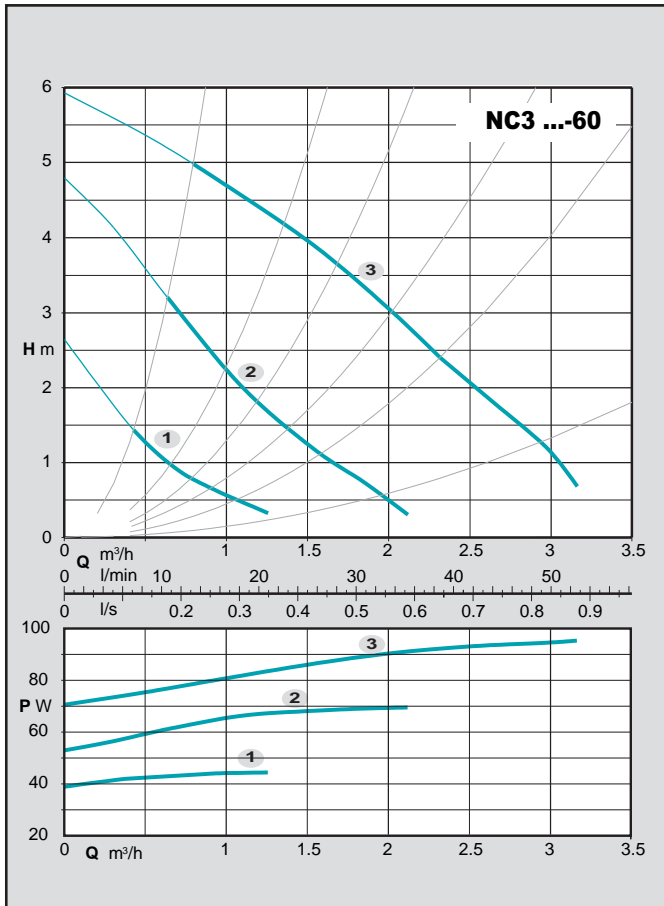
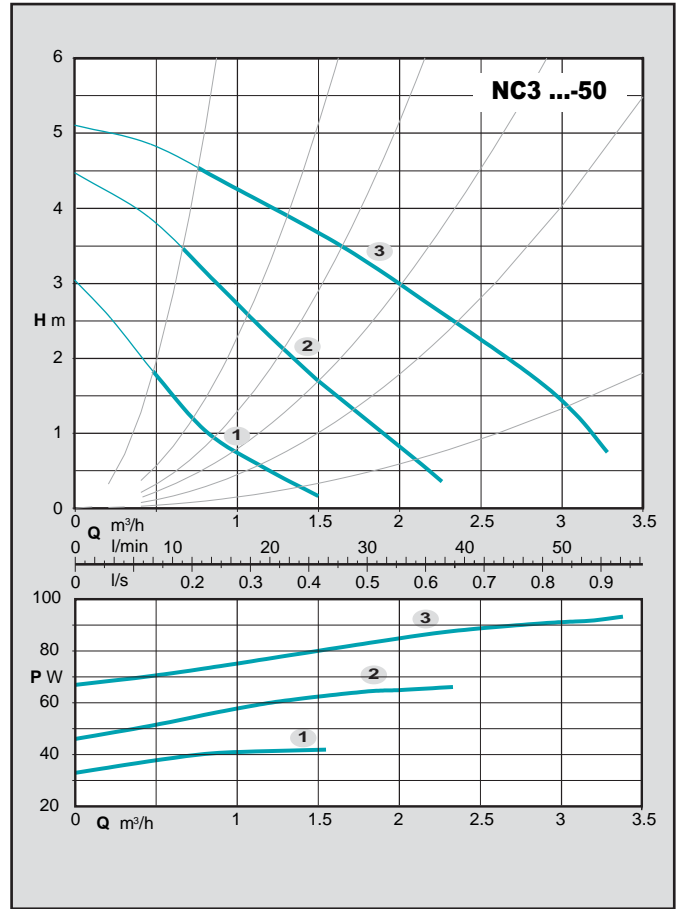
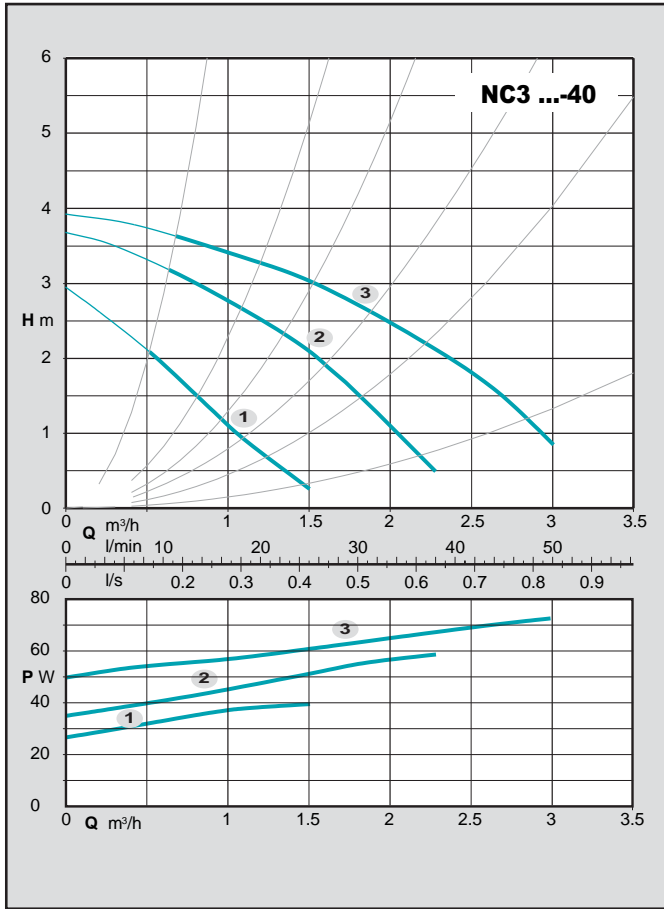

TYPE	DN	Pos.	P1 (W)	1x 230 V [A]	A mm	[kg]
NC3 15-40/130	G 1	3	70	0,30	130	2,2
NC3 25-40/130	G 1 1/2	2	59	0,26	130	2,4
NC3 25-40/180	G 1 1/2	1	41	0,18	180	2,6
NC3 15-50/130	G 1	3	91	0,38	130	2,2
NC3 25-50/130	G 1 1/2	2	65	0,28	130	2,4
NC3 25-50/180	G 1 1/2	1	42	0,18	180	2,6
NC3 32-50/180	G 2	1			180	3
NC3 15-60/130	G 1	3	95	0,41	130	2,2
NC3 25-60/130	G 1 1/2	2	70	0,30	130	2,4
NC3 25-60/180	G 1 1/2	1	44	0,20	180	2,6
NC3 32-60/180	G 2	1			180	3

Characteristic curves, dimensions and weights

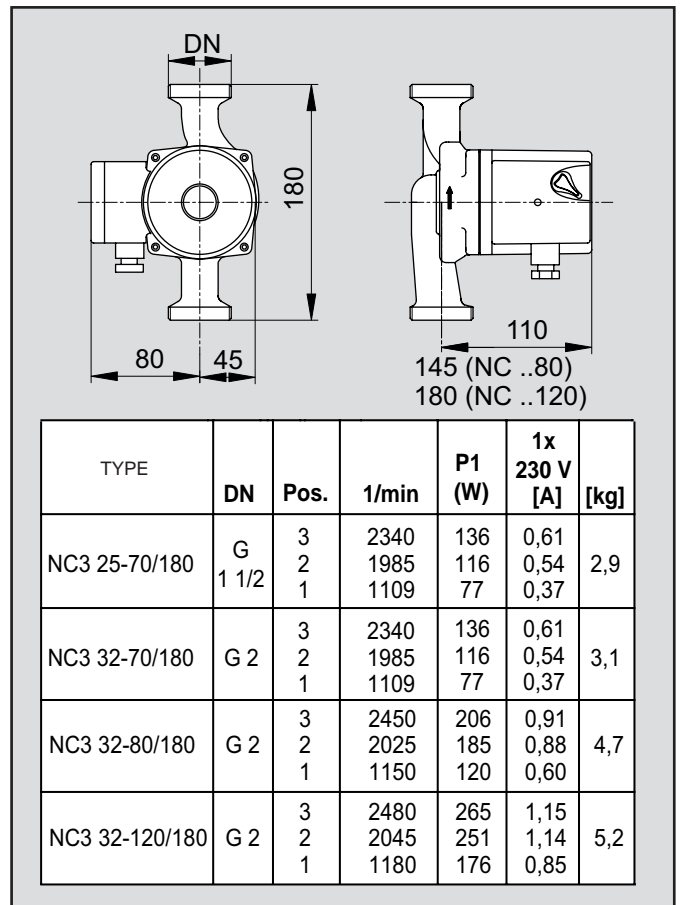
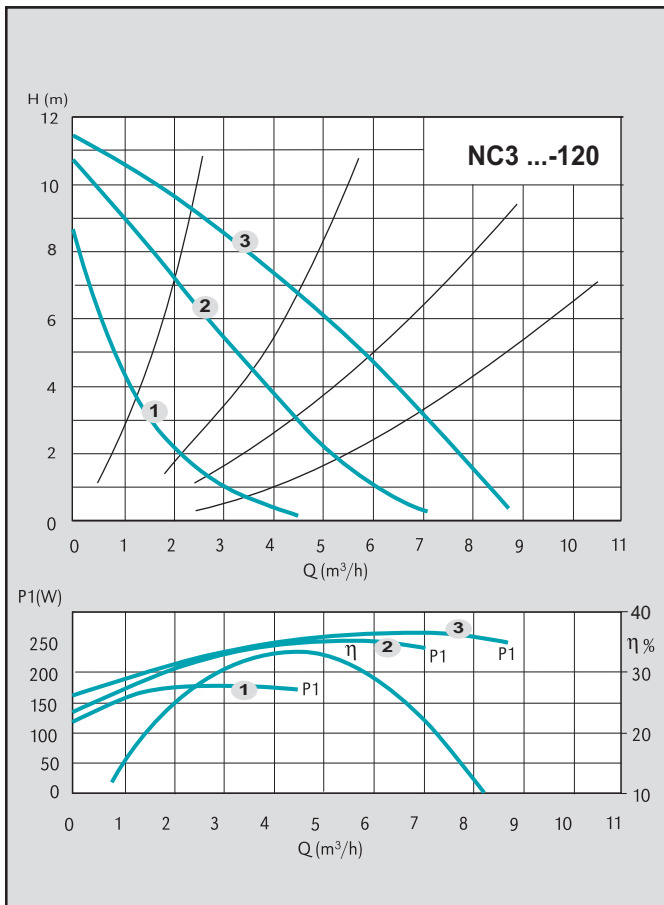
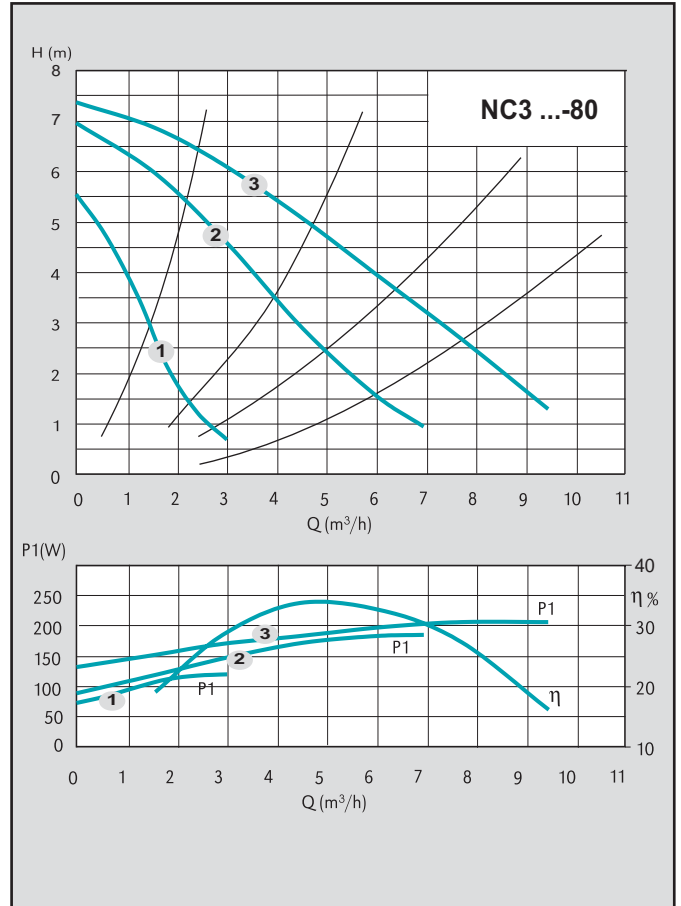
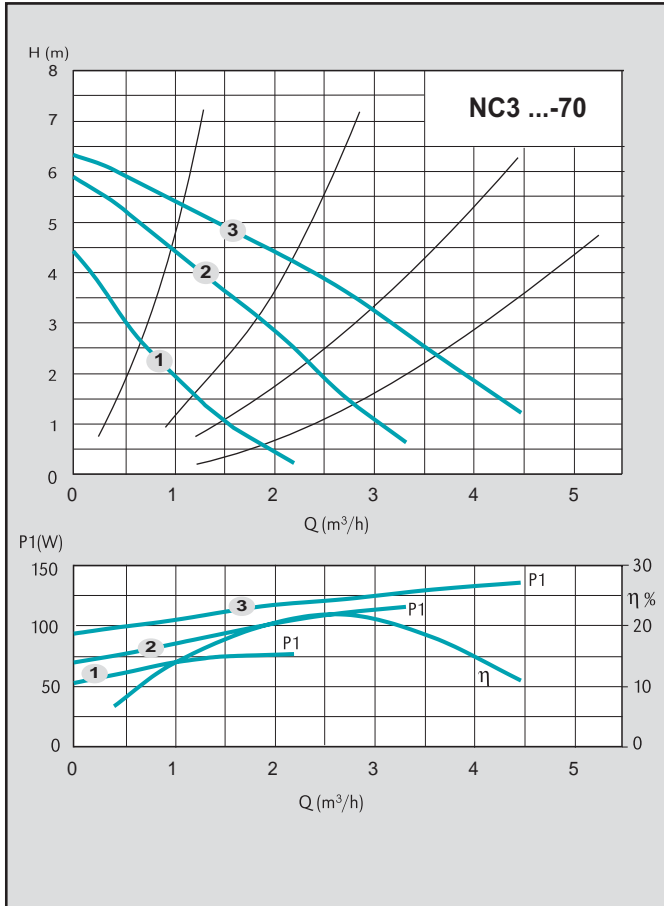

NCS3

Circulating pumps for sanitary hot water



Construction

Bronze pump casing with suction and delivery connections with the same diameter and on the same axis (in-line).
Stainless steel AISI 316 can.
Brass unions on request.

Materials	NCS3 ..-40, -50	NCS3 ...-70
Pump casing	Bronze	Bronze
Impeller	Composite	Composite
Shaft	Stainless steel	Ceramic
Bearings	Graphite	Ceramic

Installation

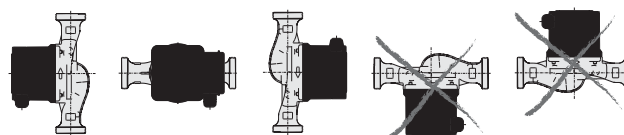

Applications

Circulation of sanitary hot water.

Operating conditions

Liquid temperature from +5 °C to +65 °C.
Ambient temperature up to 40 °C.
Sound pressure ≤ 43 dB (A).
Minimum suction pressure: 0,05 bar at 50 °C
Maximum permissible working pressure 10 bar.

Motor

2-pole induction motor, 50 Hz.
Three adjustable speeds.
NCS3: single-phase 230 V.
Insulation class H.
Protection IP 44.

Désignation

NCS3 20 - 40 / 130

Série _____
DN des orifices en mm _____
Hauteur maxi dm _____
Entraxe pour installation mm _____

Unions

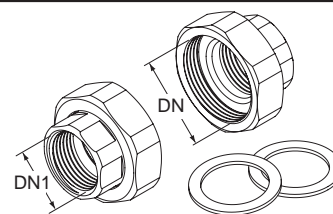

TYPE		DN	DN1
KIT G 1 - G 1/2 (NC. 15..)		G 1	G 1/2
KIT G 1 1/4 - G 3/4 (NC. 20..)		G 1 1/4	G 3/4
KIT G 1 1/2 - G 1 (NC. 25..)		G 1 1/2	G 1
KIT G 2 - G 1 1/4 (NC. 32..)		G 2	G 1 1/4

Characteristic curves, dimensions and weights

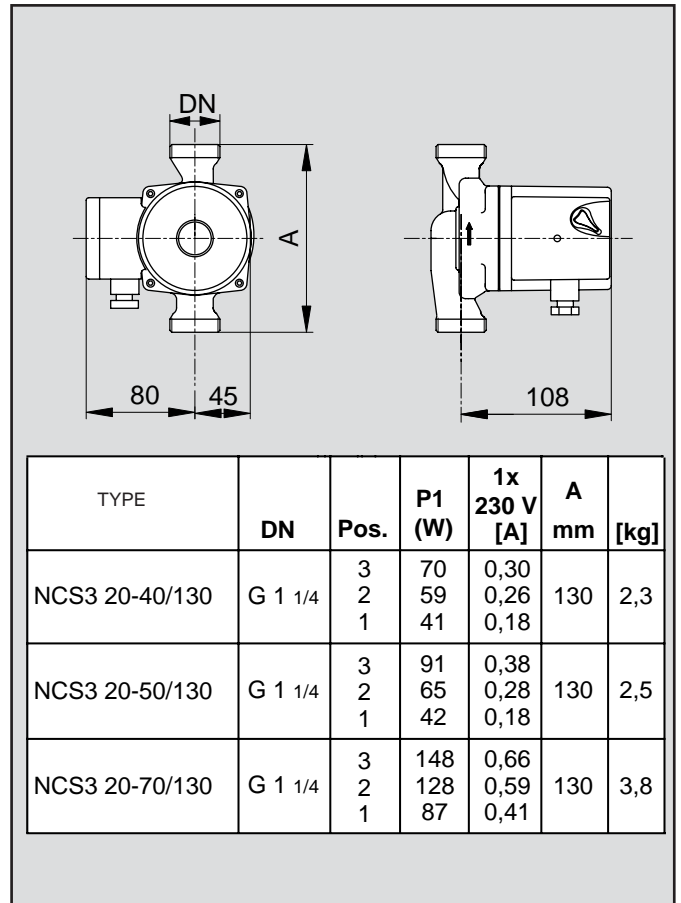
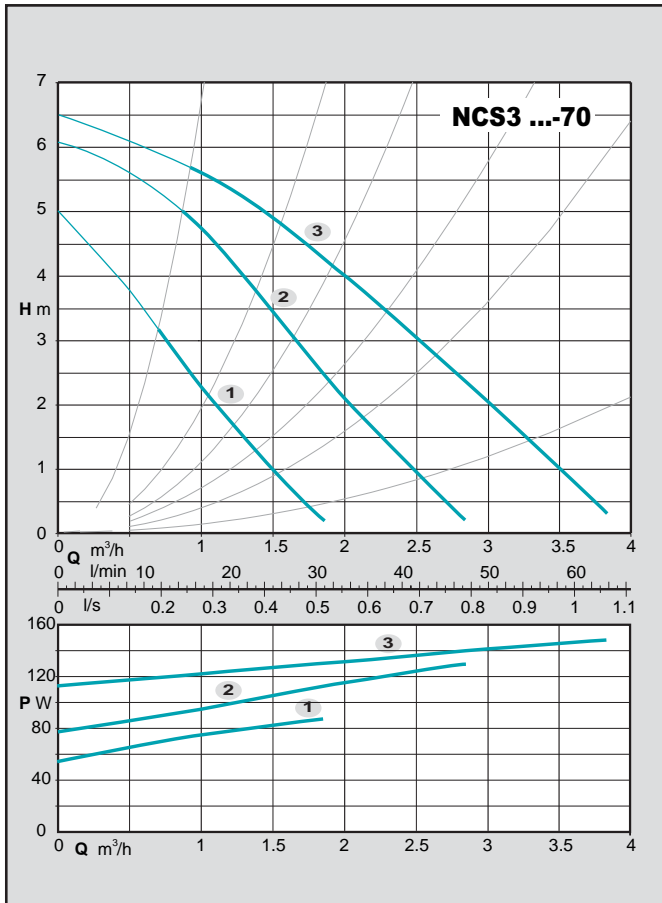
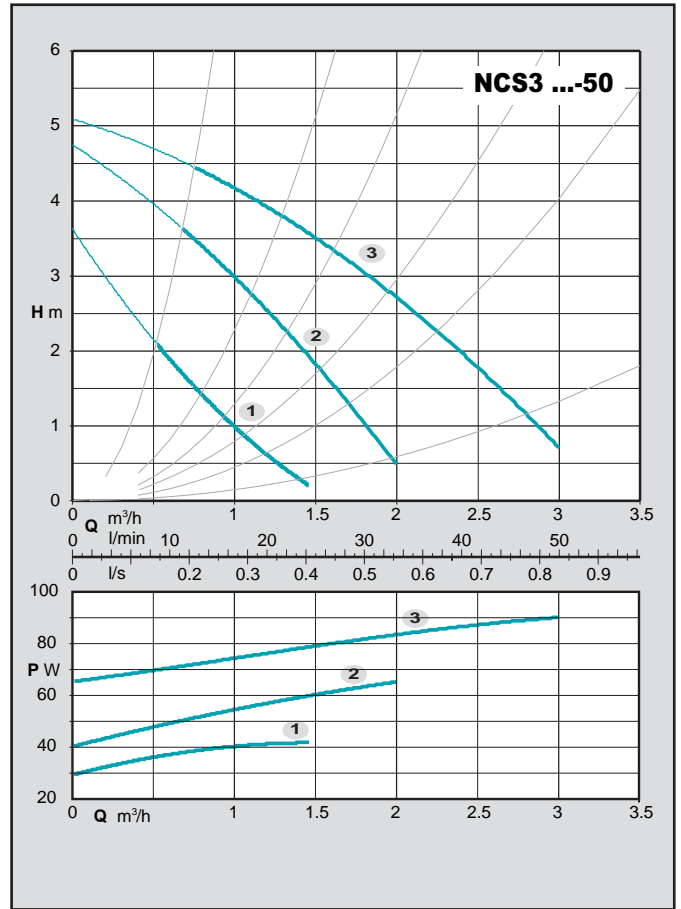
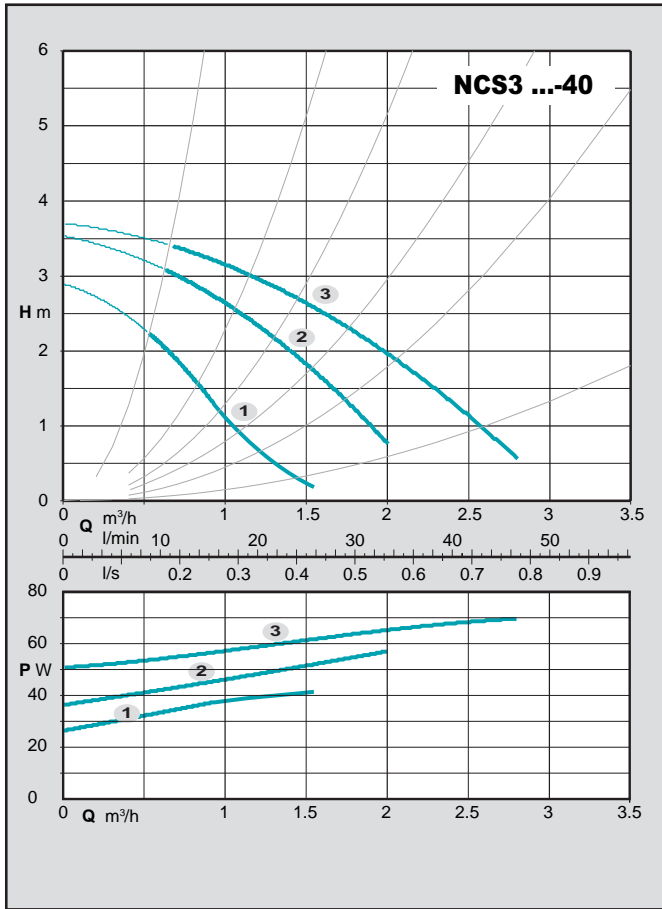



Construction

Pump casing with suction and delivery connections with the same diameter and on the same axis (in-line).

Materials:

Pump casing	Cast iron
Impeller	Stainless steel
Shaft	Stainless steel

Applications

For clean liquids, without abrasives, which are non-aggressive for the pump materials (contents of solids up to 0.2%).

For heating, conditioning, cooling and circulation plants.

For civil and industrial applications.

When low noise operation is required.

Operating conditions

Liquid temperature from -10 °C to +120 °C (in short-time duty up to + 140 °C).

Ambient temperature up to 40 °C.

Maximum glycol quantity: 50% (Mixture with more than 20% glycol content require rechecking of the pumping data).

Maximum permissible working pressure 6/10 bar.

type	Minimum suction pressure: bar		
	Temperature		
	50°C	80°C	110°C
NC 40	0,05	0,8	1,4
NC 50	0,3	1	1,6
NC 65	0,3	1	1,6
NC 80	0,3	1	1,6

Motor

2-4-pole induction motor, 50 Hz.

Three adjustable speeds.

NC: three-phase 230V or 400 V.

NCM: single-phase 230 V.

Insulation class H.

Protection IP 43.

Installation

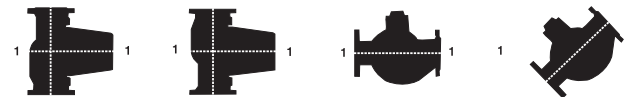

Cross section drawings

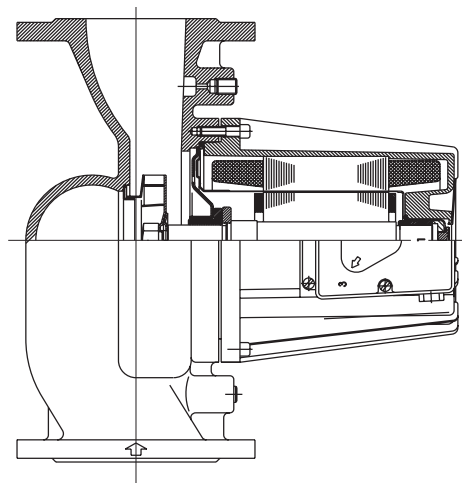

Designation

NC (M) 4 40 - 60 / 250

Series	NC (M)
Single-phase motor	4
4-pole motor	40
DN ports in mm	60
Max. head in dm	250
connection size mm	

Coverage chart

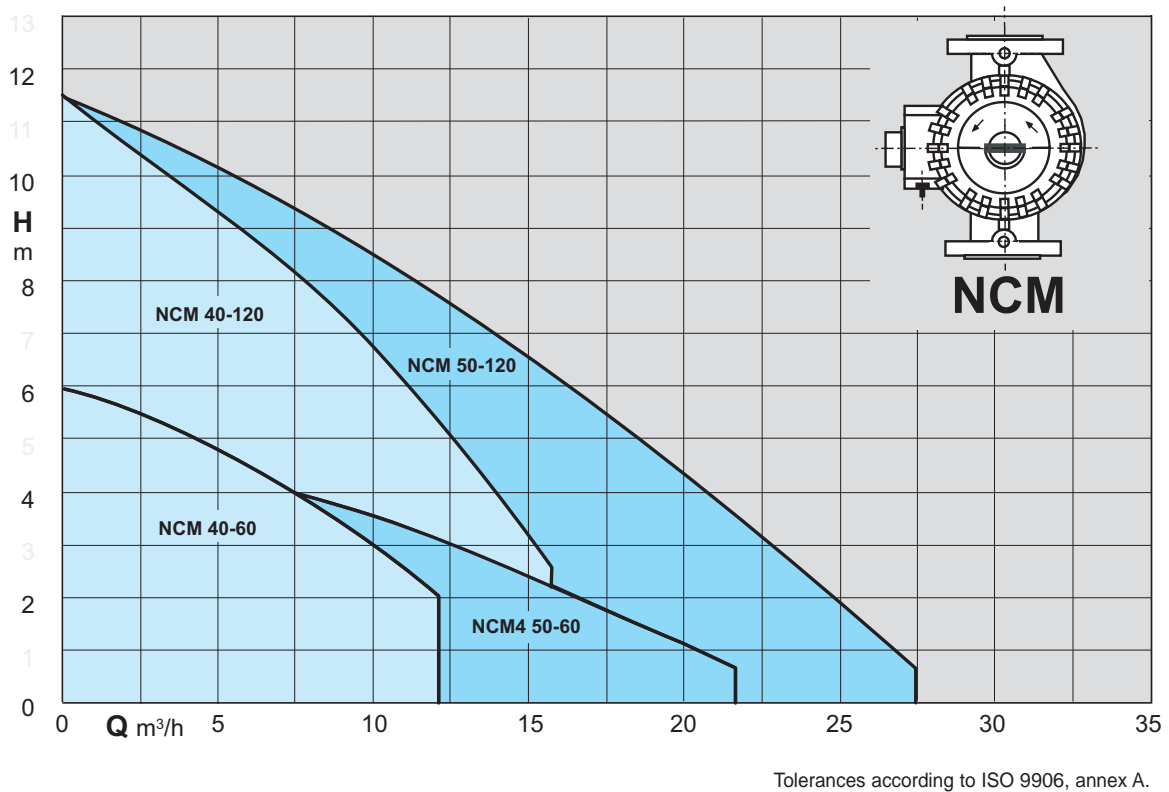
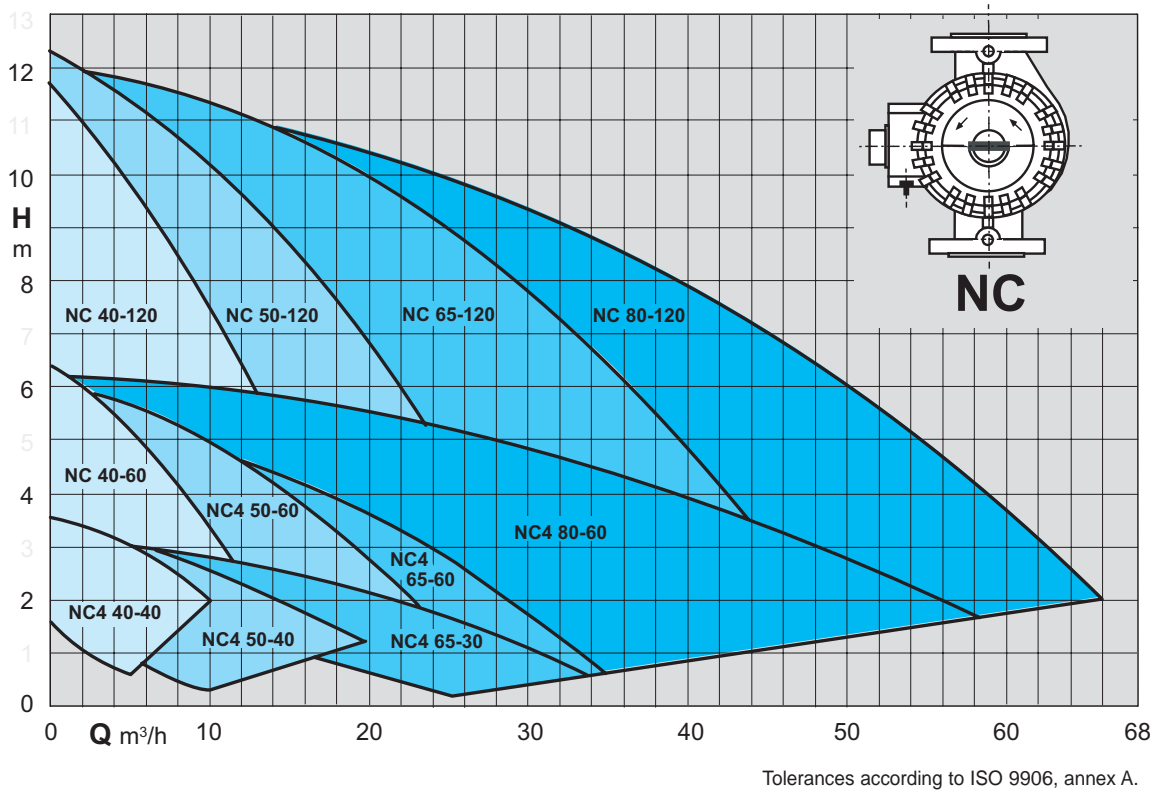

NC 40

Three speeds circulating pumps with threaded ports

Characteristic curves, dimensions and weights

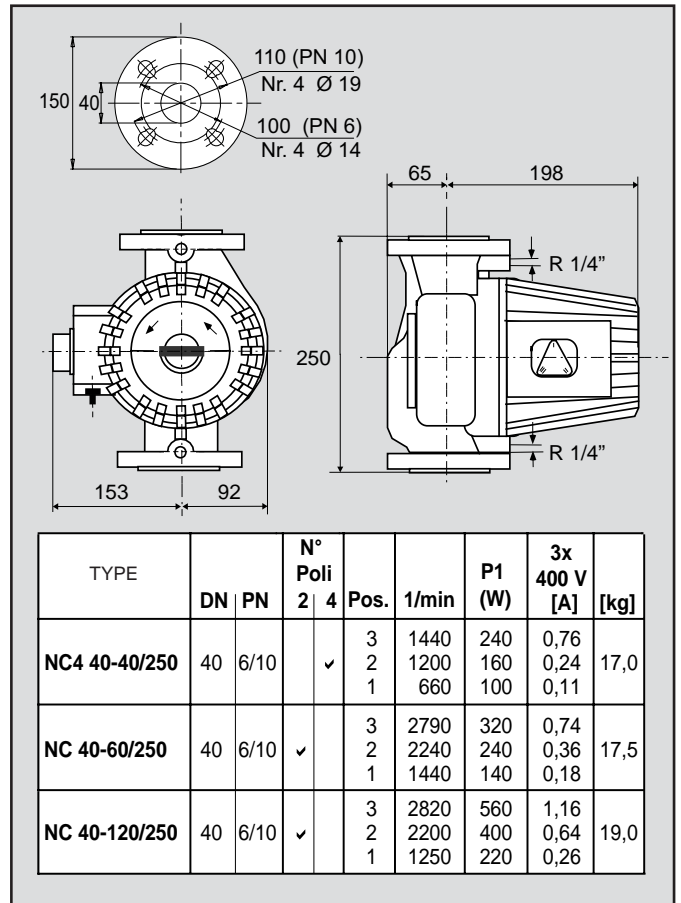
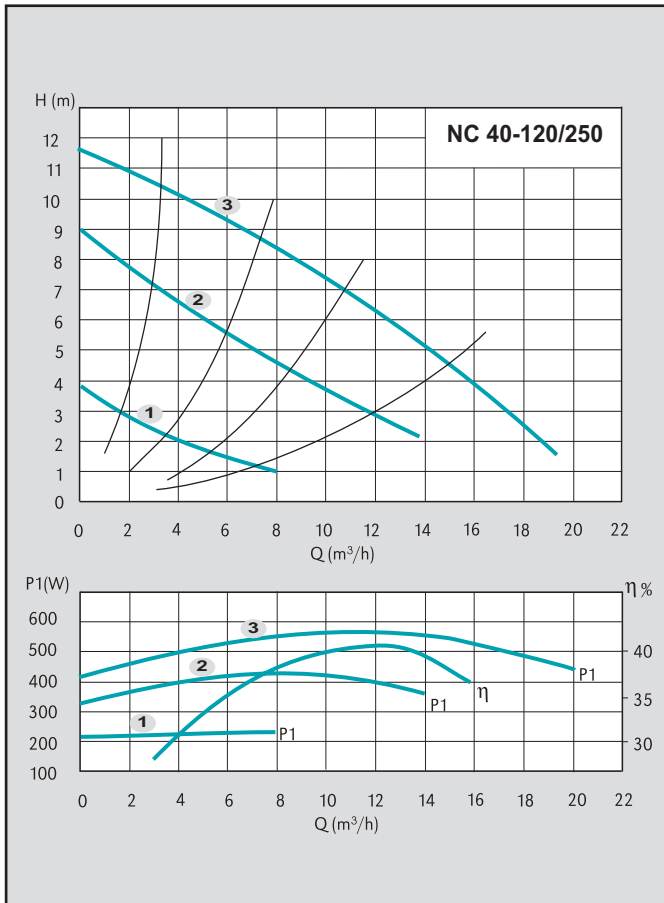
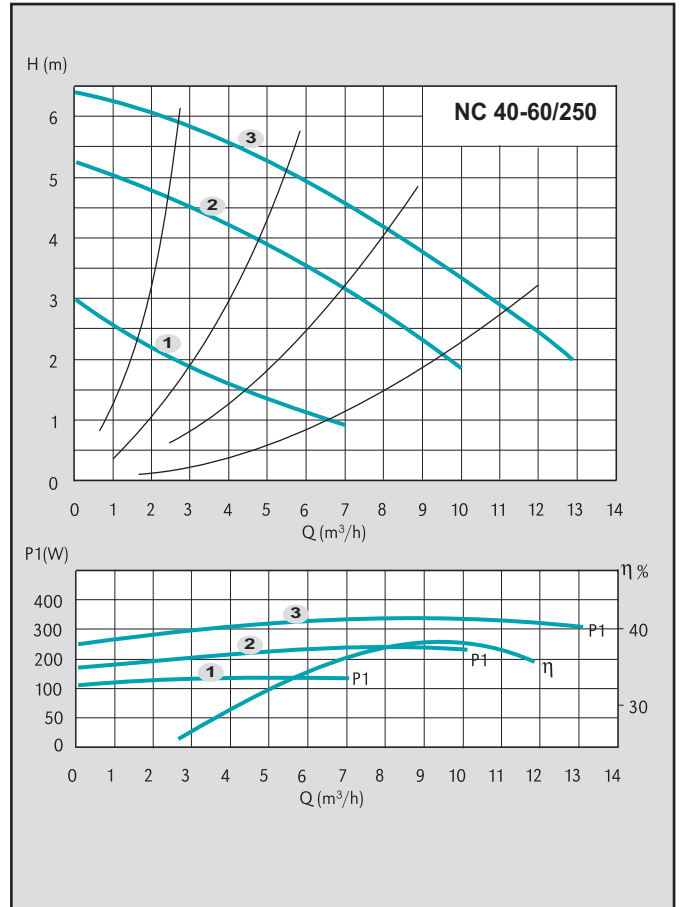
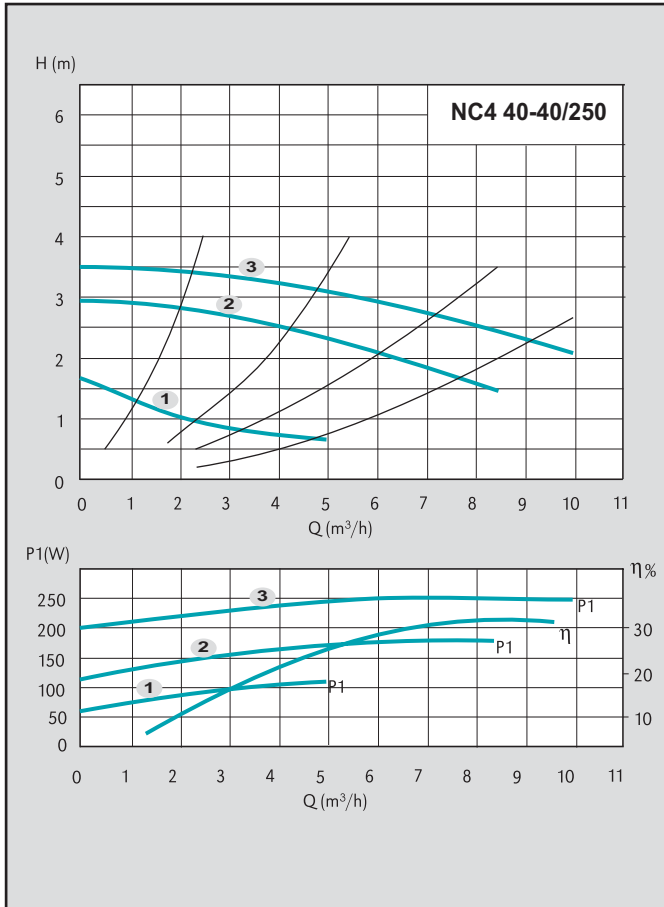

NCM 40

Three speeds circulating pumps with threaded ports

Characteristic curves, dimensions and weights

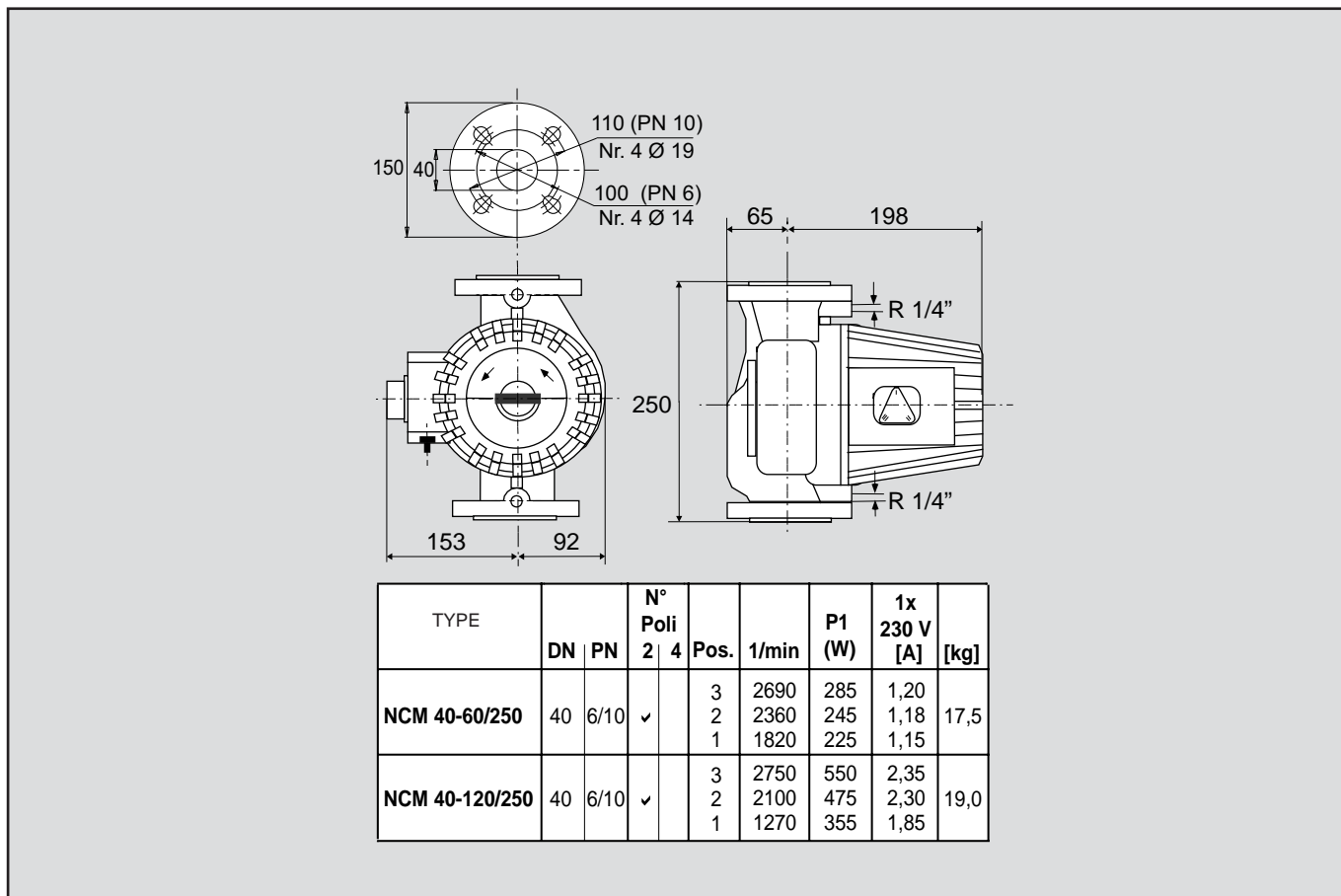
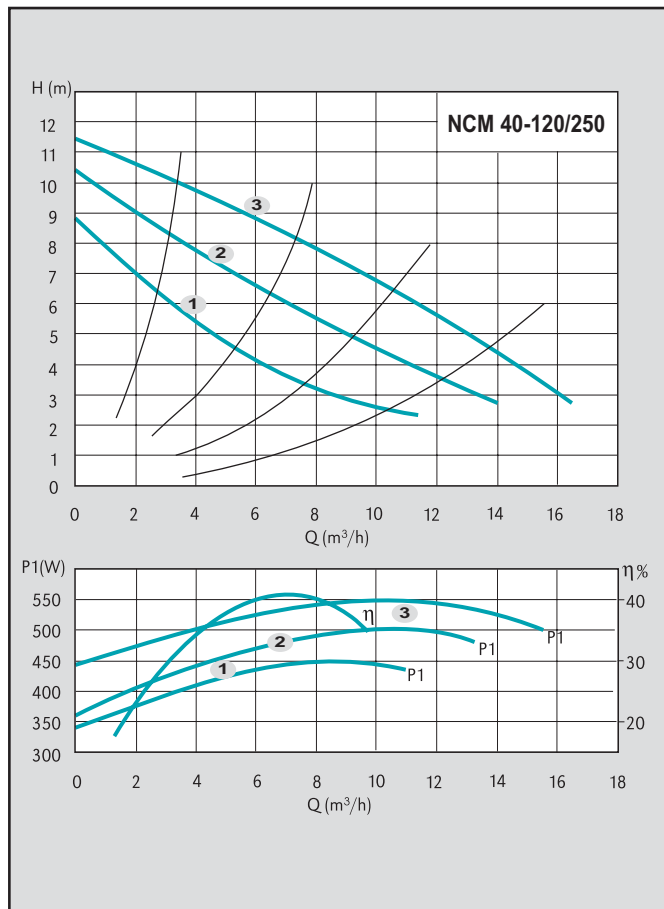
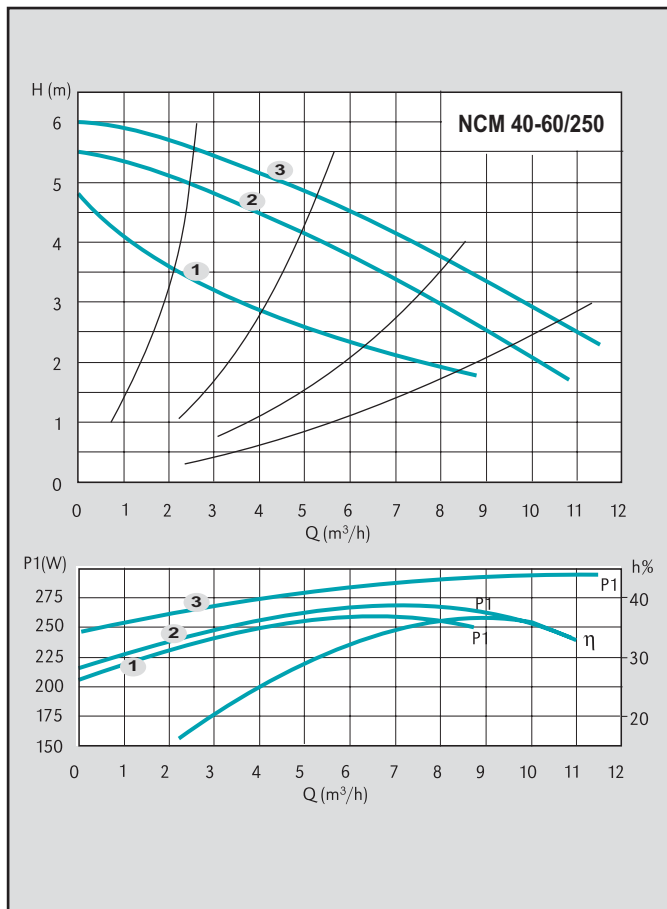

NC 50

Three speeds circulating pumps with threaded ports

Characteristic curves, dimensions and weights

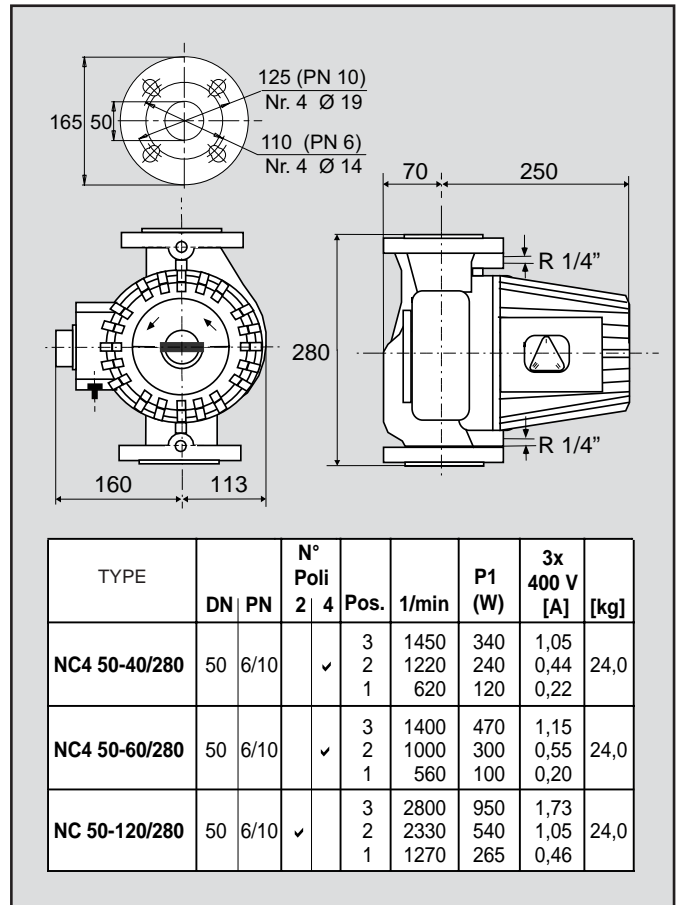
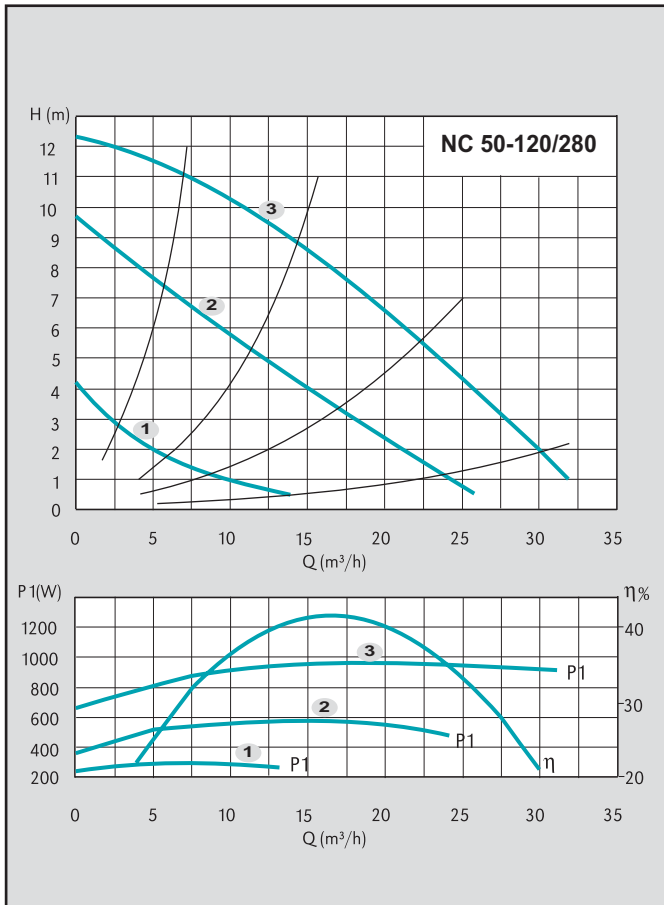
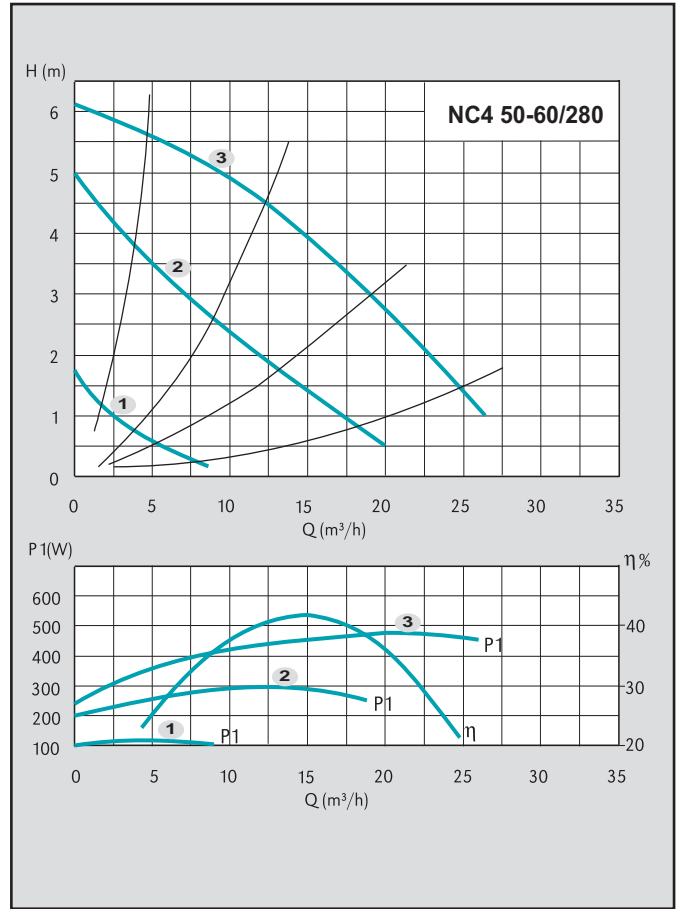
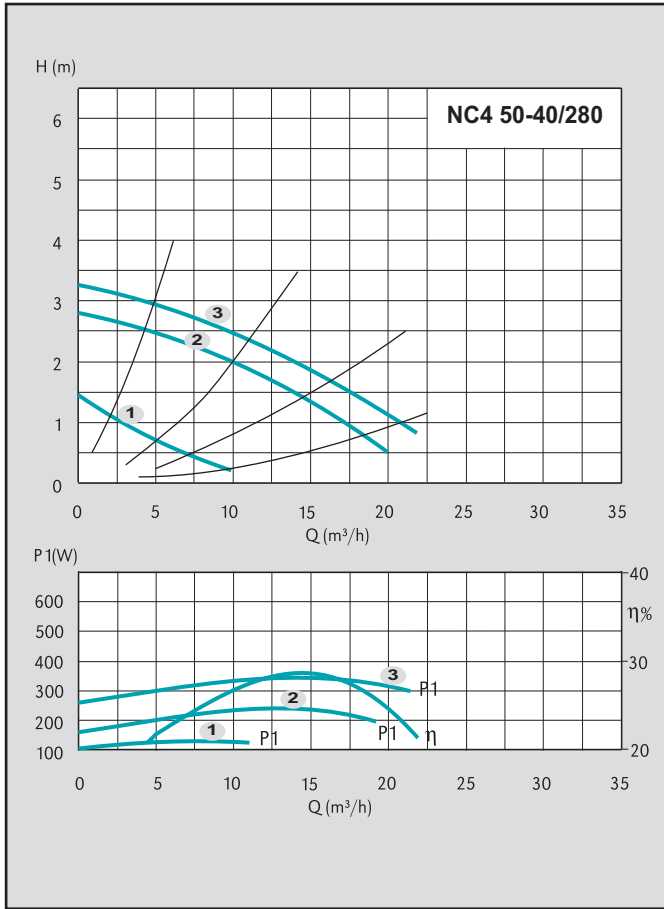

NCM 50

Three speeds circulating pumps with threaded ports

Characteristic curves, dimensions and weights

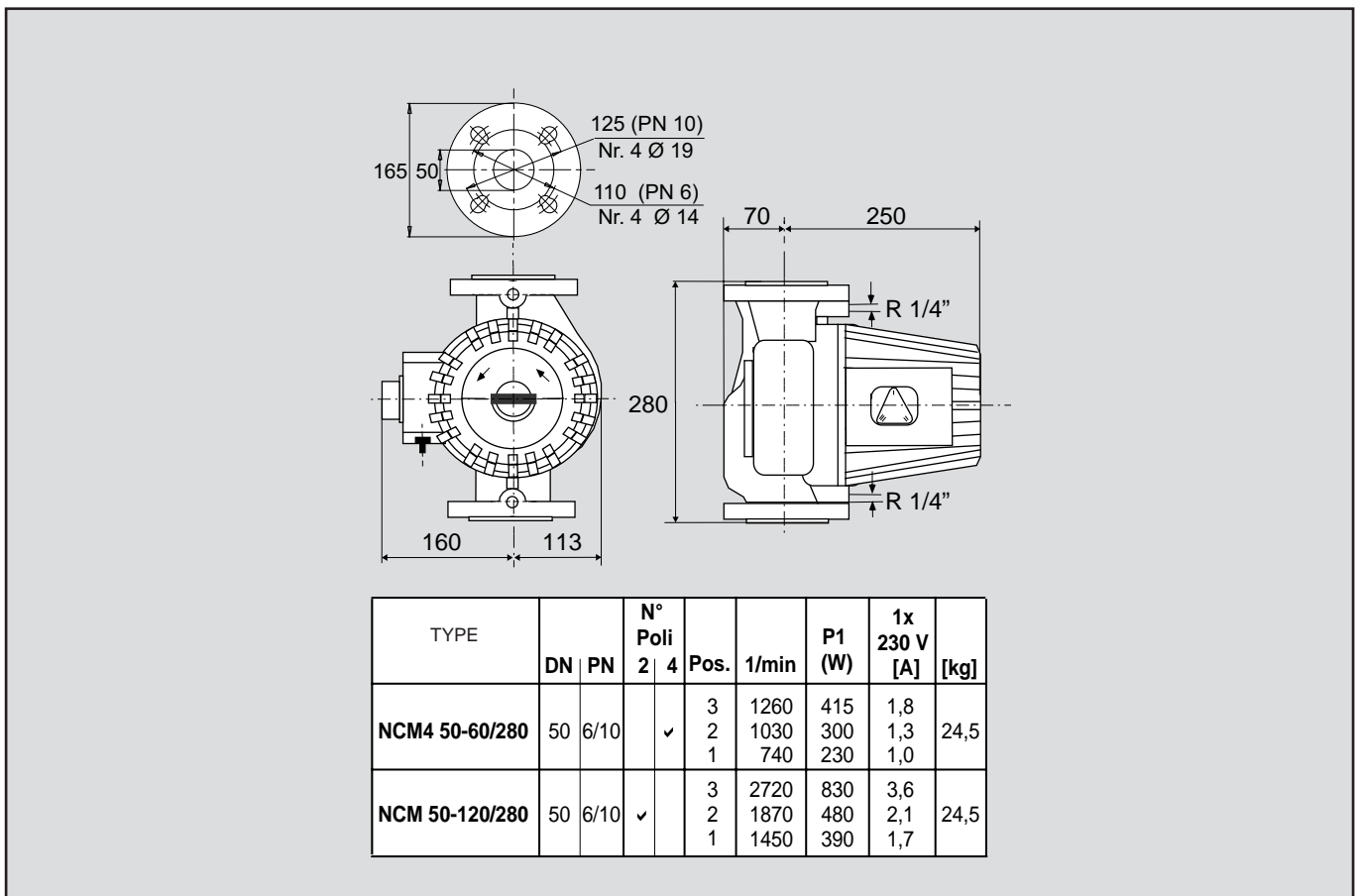
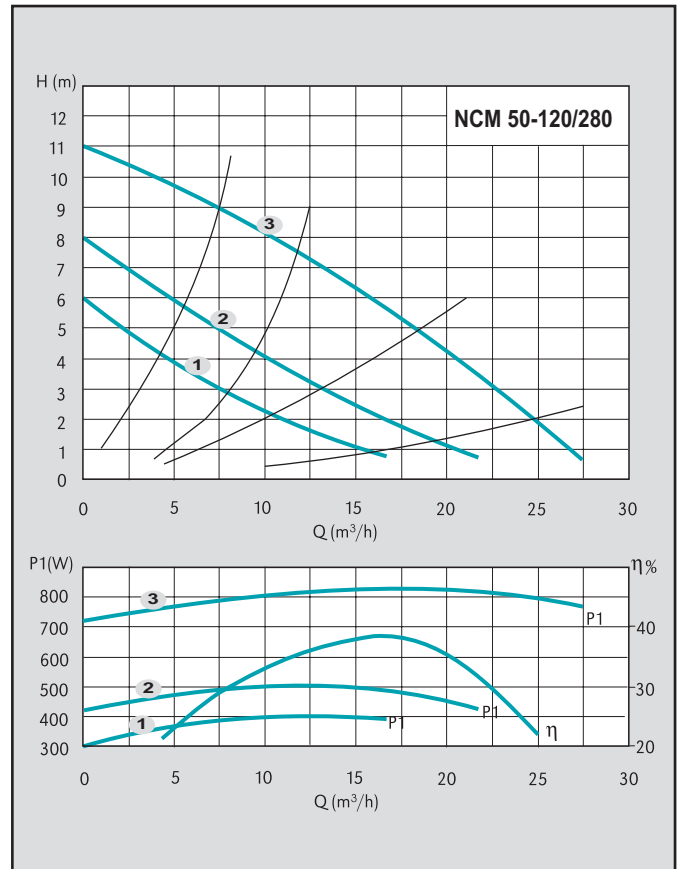
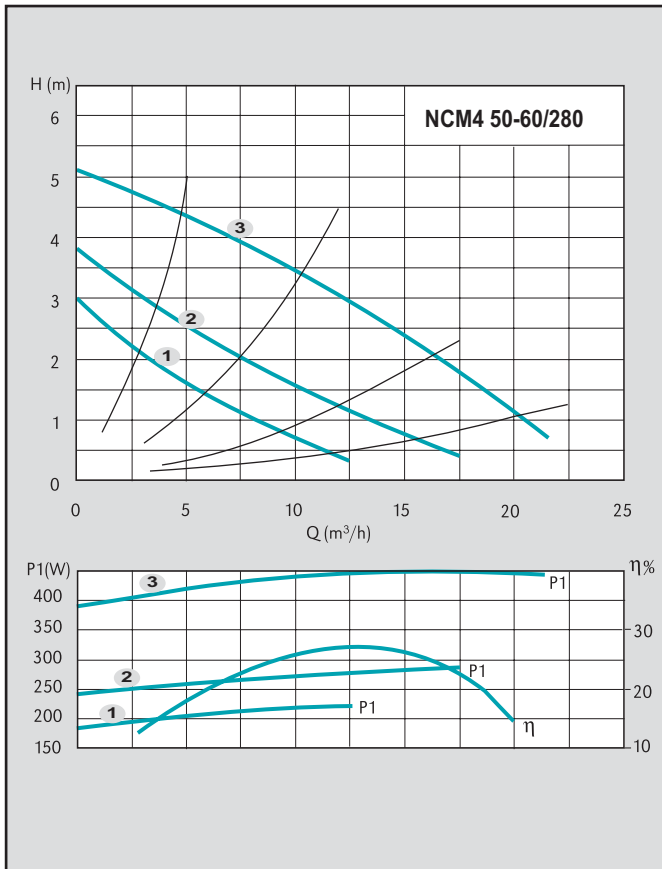

NC 65

Three speeds circulating pumps with threaded ports

Characteristic curves, dimensions and weights

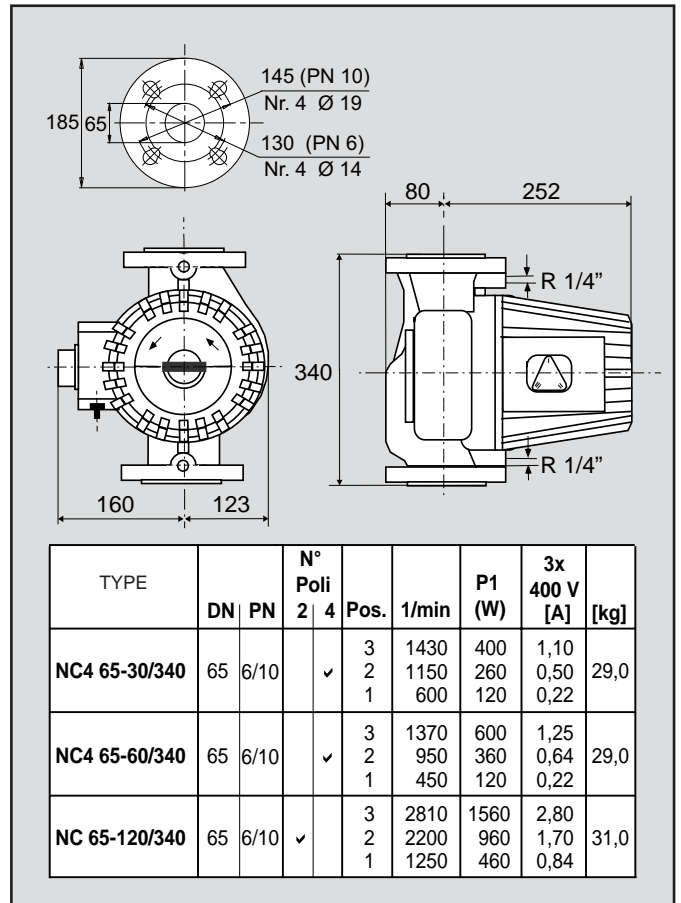
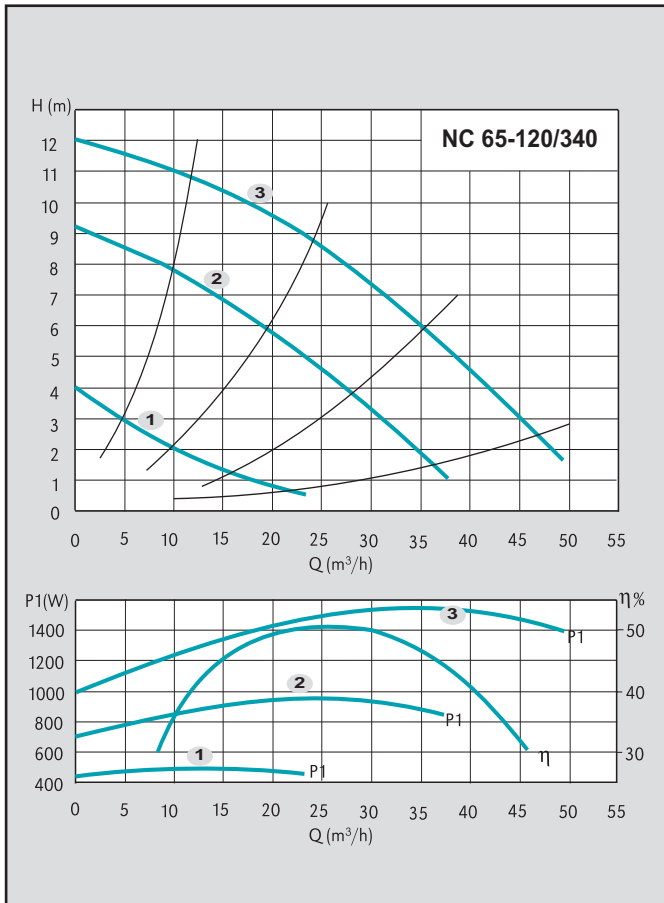
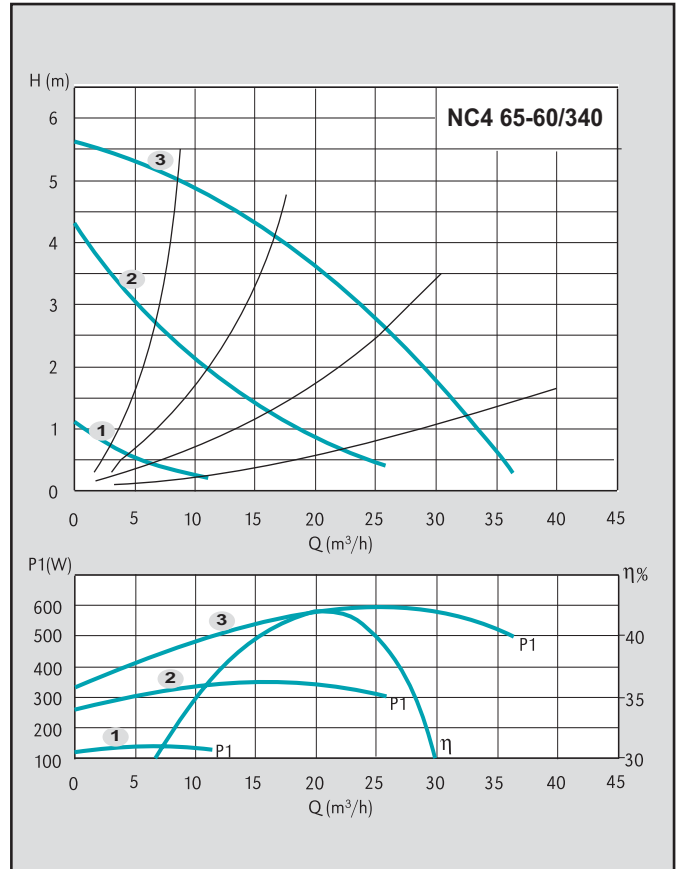
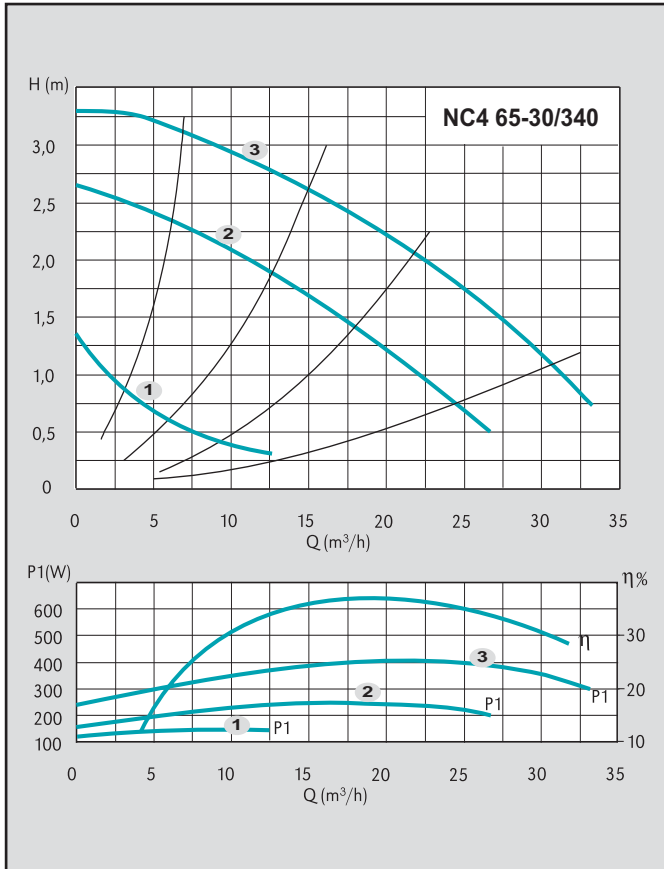

NC 80

Three speeds circulating pumps with threaded ports

Characteristic curves, dimensions and weights

