

INTEROBIZ

www.interobiz.ro

GXC, GXV

Submersible Sewage and Drainage Pumps



Construction

Single-impeller submersible pumps in chrome-nickel stainless steel, with vertical delivery port.

GXC: with two-passage impeller.

GXV: with free-flow (vortex) impeller.

Double shaft seal with interposed oil chamber.

Applications

For clean and dirty water, also containing solids up to 35 mm grain size.

The GXV free-flow impeller construction is particularly suitable for liquids with a high solid content or with filamentous particles. This construction (with smooth surfaces in rolled-stainless steel and easy access for cleaning) is also suitable for certain uses in the food industry.

Operating conditions

Liquid temperature up to 35 °C.

Minimum immersion depth: 250 mm.

Maximum immersion depth: 5 m.

Continuous duty (with submerged motor).

Motor

2-pole induction motor, 50 Hz (n = 2800 rpm).

GXC, GXV: three-phase 230 V ± 10%;

three-phase 400 V ± 10%;

GXCM, GXVM: single-phase 230 V ± 10%,

with float switch and thermal protector.

Control box with capacitor.

Cable: H07 RN8-F, 4G1 mm², length 10 m.

Insulation class F.

Protection IP X8 (for continuous immersion)

Triple impregnation humidity-proof dry winding.

Constructed in accordance with: EN 60335-2-41.

Special features on request

- Other voltages.
- Frequency 60 Hz (only for GXV, as per 60 Hz data sheet).
- Other mechanical seal.
- Cable length 20 m.
- Sleeve and clamp for flexible hose.

Materials

Component	Material
Pump casing	Chrome-nickel steel 1.4301 EN 10088 (AISI 304)
Casing cover	
Impeller	
Motor jacket	
Jacket cover	
Handle	Chrome-nickel steel 1.4305 EN 10088 (AISI 303)
Shaft	
Mechanical seal	
Seal lubrication oil	Ceramic alumina/Carbon/NBR
	Oil for food/pharmaceutical machinery

Characteristic curves $n \approx 2800$ rpm

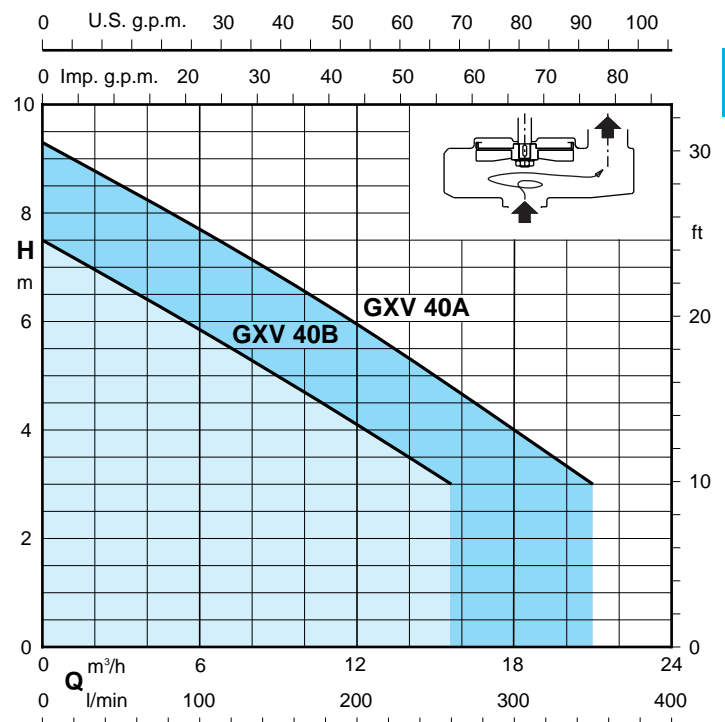
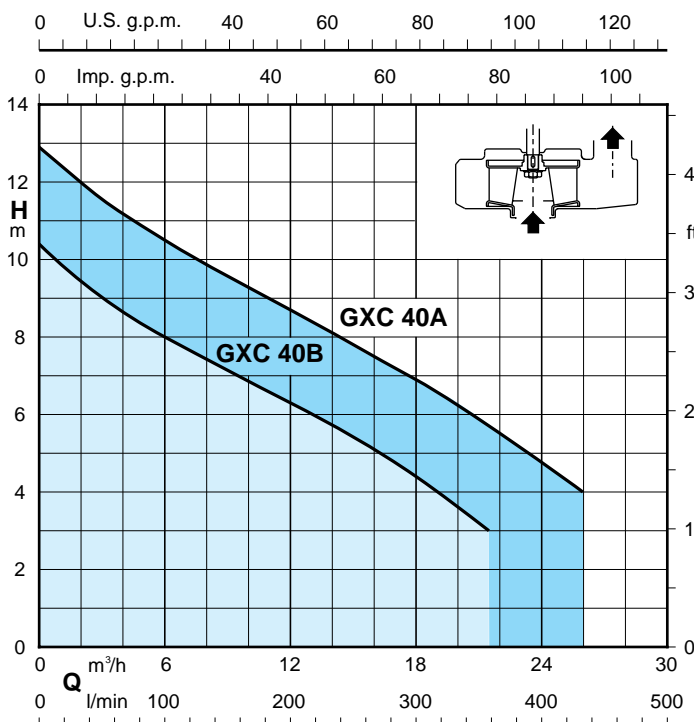

GXC, GXV

Submersible Sewage and Drainage Pumps

Performance $n \approx 2800$ rpm

3~	230 V 400 V		1~	230 V	Capacitor		P ₁	P ₂		Q												
	A	A			A	μ F		V	kW		kW	HP	m ³ /h	l/min	0	3	6	9	12	15	18	21
GXC 40B	2,7	1,6	GXCM 40B	4,6	20	450	0,85	0,55	0,75	H	10,4	9	8	7,1	6,3	5,4	4,4	3,2				
GXC 40A	3,8	2,2	GXCM 40A	6,3	25	450	1,3	0,9	1,2	m	12,9	11,6	10,5	9,5	8,7	7,8	6,9	5,9	4,7	4		

3~	230 V 400 V		1~	230 V	Capacitor		P ₁	P ₂		Q												
	A	A			A	μ F		V	kW		kW	HP	m ³ /h	l/min	0	3	6	9	12	15	18	21
GXV 40B	2,7	1,6	GXVM 40B	4,6	20	450	0,85	0,55	0,75	H	7,5	6,7	5,9	5	4,1	3,2						
GXV 40A	3,8	2,2	GXVM 40A	6,3	25	450	1,3	0,9	1,2	m	9,3	8,5	7,7	6,8	5,9	5	4	3				

P₁ Max. power input.

P₂ Rated motor power output.

Density $\rho = 1000$ kg/m³.

Kinematic viscosity $\nu = \max 20$ mm²/sec.

Dimensions and weights

Stationary installation

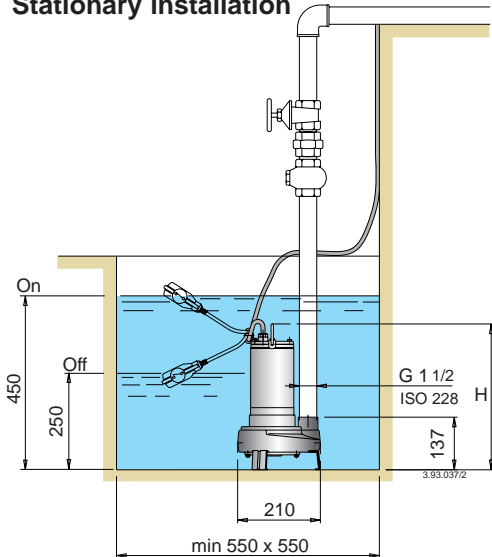

Transportable installation

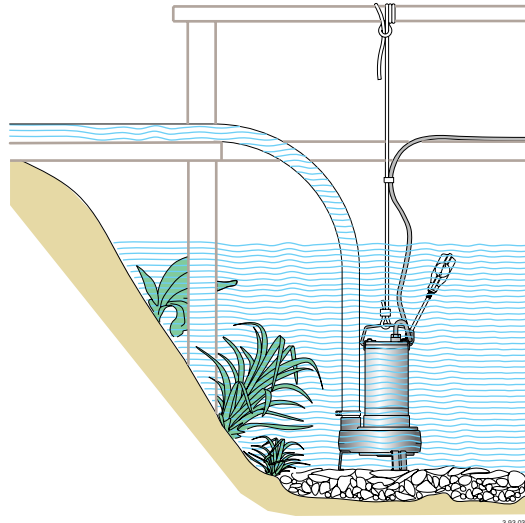

TYPE	H mm	kg (1)
GXC 40B	380	10,1
GXC 40A	405	11,7
GXCM 40B	380	11,9
GXCM 40A	405	13,2
GXV 40B	380	9,9
GXV 40A	405	11,5
GXVM 40B	380	11,7
GXVM 40A	405	13,0

1) With cable length: 10 m

Control box for single-phase pumps

Pump	Control box	Capacitor	
GXCM 40B	QM 11	20 μ F	450 V
GXVM 40B			
GXCM 40A	QM 12	25 μ F	450 V
GXVM 40A			

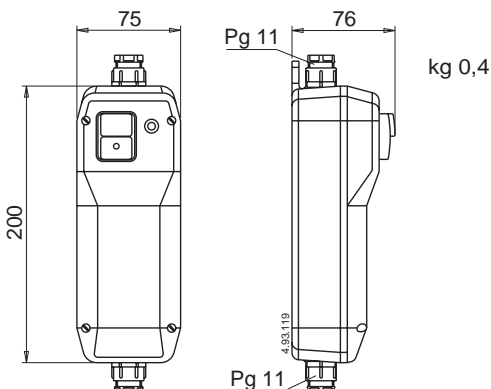

Low cost installation

Vertical, upward delivery port for installation in small pits, without the need for an elbow on the pump. Handle for transport and installation (in suspended position or with flexible hose) by means of a safety rope for securing and lifting the pump.

Reliable

All parts in contact with the liquid, inside and outside the pump, are in chrome-nickel stainless steel. With corrosion-resistant seal rings and heavy polychloroprene sheathed power cable.

Extra safety

The double shaft seal with interposed oil chamber separates the motor from the water and provides further protection against accidental operation when dry.

