

**INTEROBIZ**

[www.interobiz.ro](http://www.interobiz.ro)



### Construction

Submersible motor pumps for deep wells of 6" (DN 150 mm) and 8" (DN 200 mm), with external jacket and stages in stainless steel AISI 304 or AISI 316.

### Impellers

Radial impellers	Mixed flow impellers
6SDX 13-18-27	6SDX 45-60, 8SDX 78-97

**Connection:** Screwed connection ISO 228

Delivery casing with built-in non-return valve.

6" pumps with stainless steel external jacket and suction lantern as one piece only.

### Applications

For water supply.

For civil and industrial applications.

For fire fighting applications.

For irrigation.

### Operating conditions

Liquid temperature up to 25 °C.

Max. sand quantity into the water: 50 g/m<sup>3</sup>.

Continuous duty.

### 6", 8", 10" rewindable motor CS series

2-pole induction motor, 50 Hz (n = 2900 rpm).

With water wetted winding in rewindable execution.

Sized for connection to the pumps according to NEMA Standards.

Standard voltages:

- three-phase 400 V; 400/690 V.

Voltage tolerance : +6% / -10%.

Recommended type of starting for powers from 7.5 kW:

star/delta, soft start, impedance starting, autotransformer.

Motor	6"	8"	10"
Max. Liquid temperature	25 °C	25 °C	25 °C
Max. starts per hour	15	15	10
Cooling : minimum flow velocity	16 cm/s	20 cm/s	20 cm/s

Insulation PVC coated wire for 6-8-10" motors.

Protection IP 68.

### Cable

Motor 400V 50 Hz	Section	Length
6CS 4 ÷ 22 kW	3 + 1 x 4 mm <sup>2</sup>	3,5 m
6CS 26 ÷ 30 kW	3 + 1 x 6 mm <sup>2</sup>	3,5 m
8CS 37 - 45 kW	3 + 1 x 10 mm <sup>2</sup>	4 m
8CS 51 ÷ 59 kW	3 + 1 x 16 mm <sup>2</sup>	4 m
8CS 66 - 75 kW	3 + 1 x 25 mm <sup>2</sup>	4 m
8CS 92 kW	3 + 1 x 35 mm <sup>2</sup>	4 m
10CS 110 kW	3 + 1 x 50 mm <sup>2</sup>	4 m

### Materiales

Components	6SDX	6SDX..N	8SDX..N
External jacket	Cr-Ni steel	Cr-Ni-Mo steel	
Suction lantern	AISI 304	AISI 316	
Upper cover	Cr-Ni-Mo steel AISI 316		-
Strainer	Cr-Ni-Mo steel		
Delivery casing	AISI 316		
Valve set	NBR		
O-ring valve	NBR		
Shaft	Cr-Ni-Mo steel	AISI 316	Cr-Ni-Mo steel AISI 329
Coupling set	Cr-Ni-Mo steel AISI 316/329		
Diffuser	Cr-Ni steel	Cr-Ni-Mo steel	
Impeller	AISI 304	AISI 316	
Stage casing	Teflon (PTFE)		
Wear ring	NBR		
Bearing bush	Cr-Ni-Mo steel		
Cable guard	AISI 316		
Screws	AISI 316		

### CS Motor

Components	6", 8", 10"
External frame	Cr-Ni steel AISI 304 (Fe P01 plate motor 10")
Supports	GJL 200 EN 1561
Shaft	Hardened and tempered Cr steel AISI 420
Thrust bearing	Oscillation pads
Bushings	Graphite (Bronze for 8" motor of 51-59-66 kW)

### Special features on request

- Other voltages.

- 60 Hz frequency.

- Other temperatures.

- Motor FK series.

### Designation

Ø of the well in inches \_\_\_\_\_ 6 SDX 13 / 17 N  
 Series \_\_\_\_\_  
 Stage identification \_\_\_\_\_  
 Number of stages \_\_\_\_\_  
 Cr-Ni-Mo steel AISI 316 construction \_\_\_\_\_

Coverage chart  $n \approx 2900$  rpm

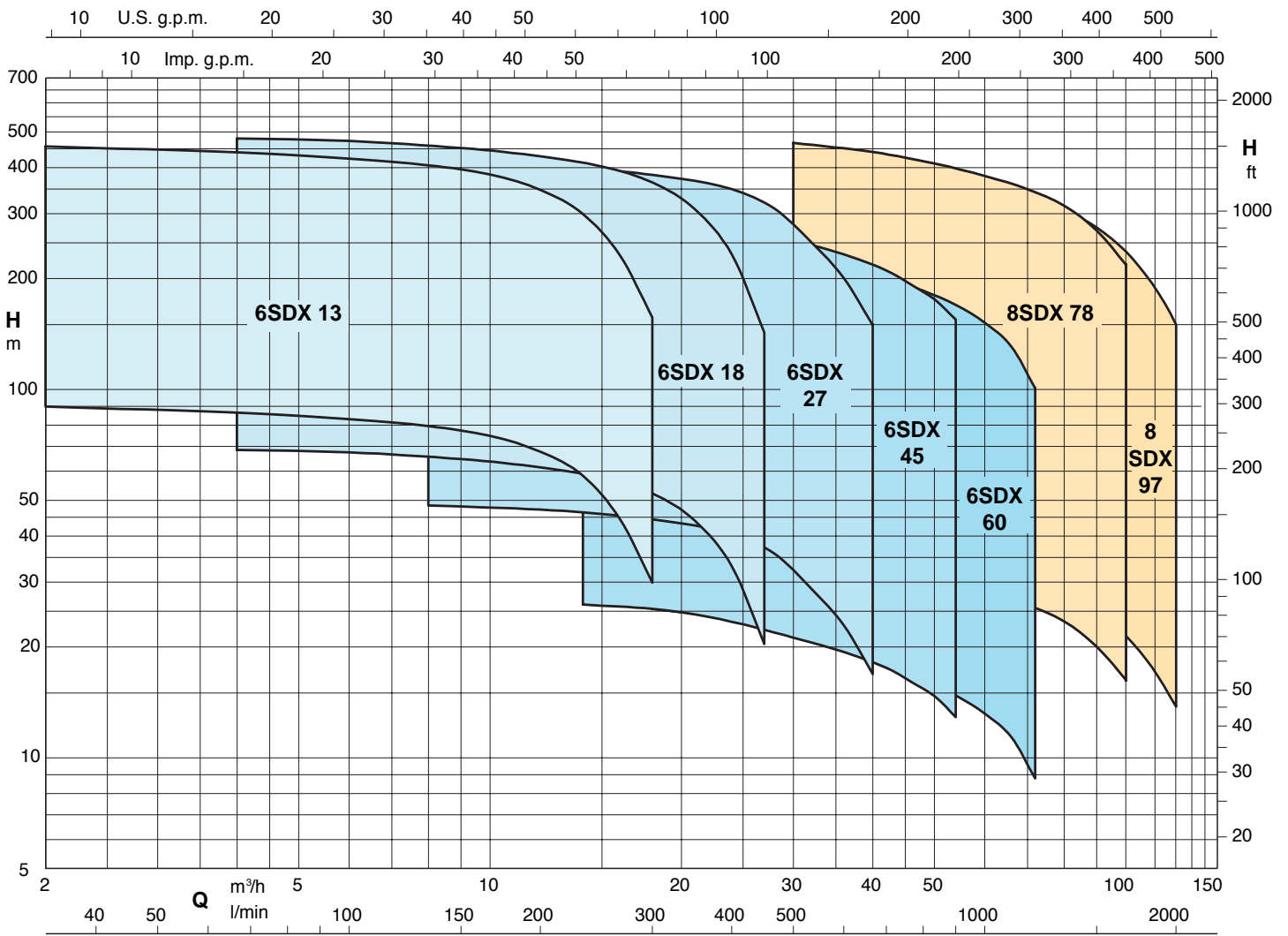

72.1161

# 6SDX 13

Submersible pumps for deep wells of 6"

## Characteristic curves, performance $n \approx 2900$ rpm, dimensions and weights

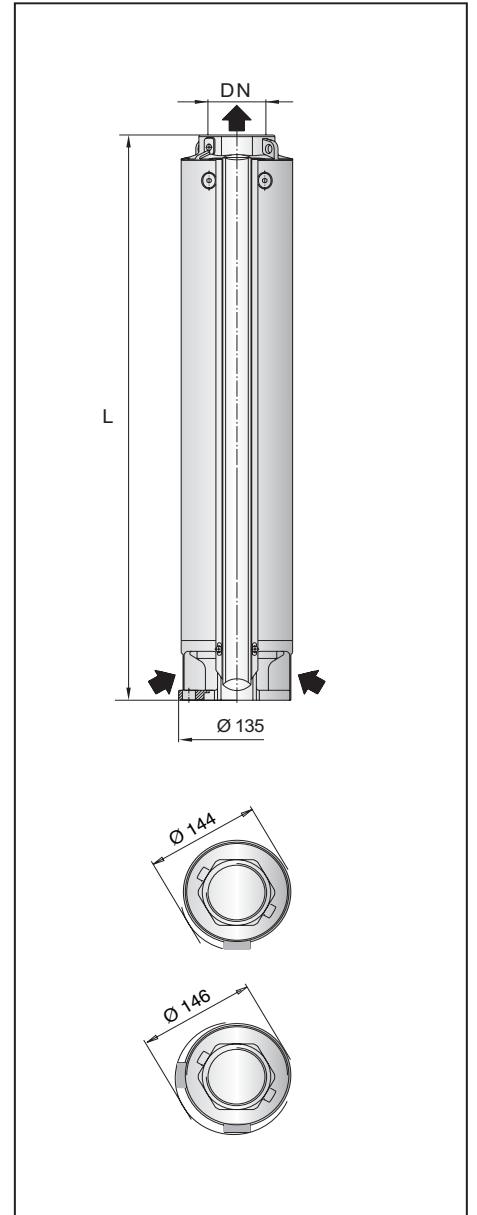
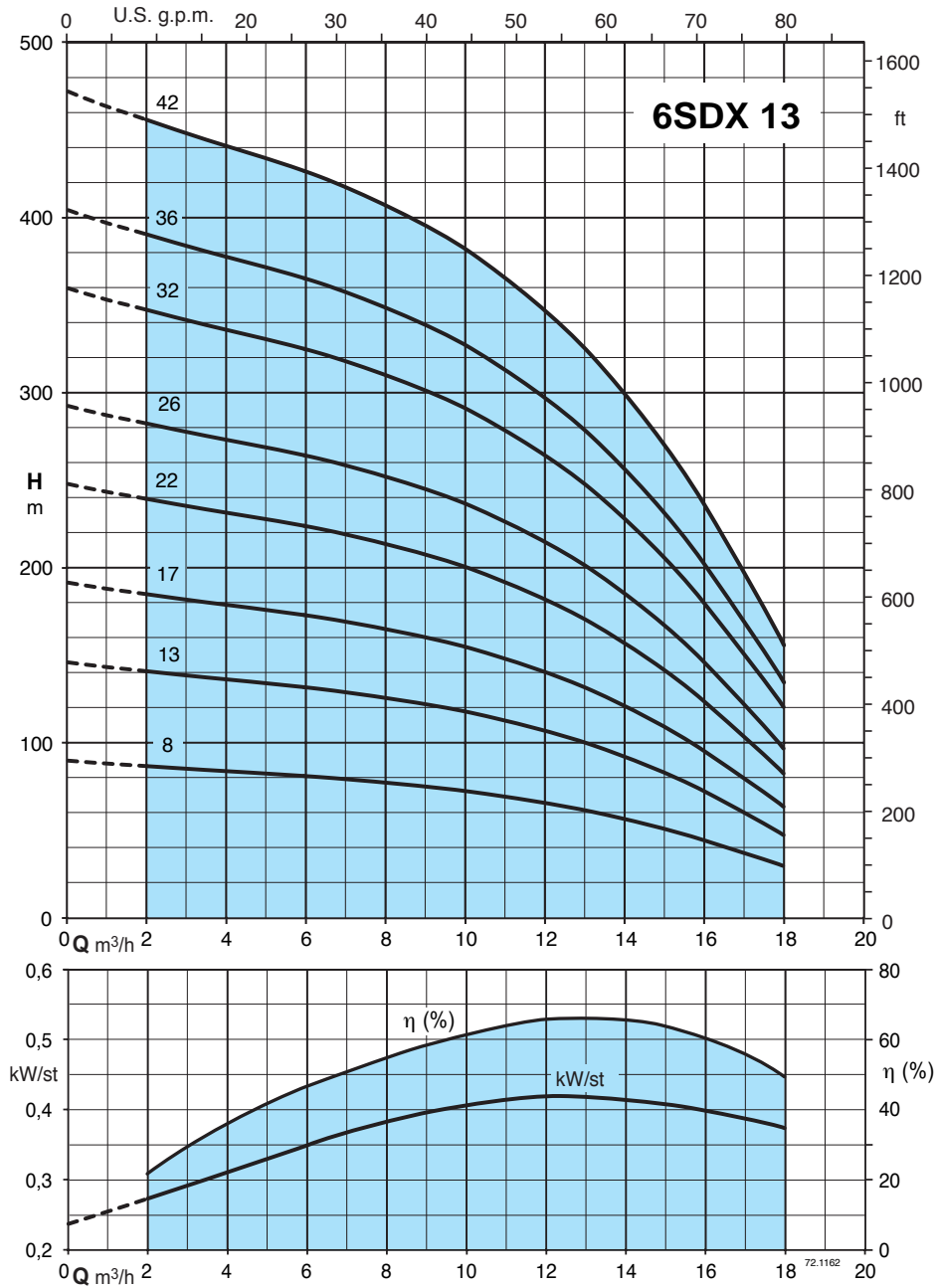

3 ~	P2		Q m³/h l/min	n ≈ 2900 1/min										
	kW	HP		0	2	4	6	8	10	12	14	16	18	
				0	33,3	66,6	100	133	166	200	233	266	300	
6SDX 13/8	4	5.5	H m	89,7	86,7	83,8	81,1	77,5	72,7	66,3	57,1	45	29,7	
6SDX 13/13	5.5	7.5		146	141	136	132	126	118	108	92,9	73	48,3	
6SDX 13/17	7.5	10		191	184	178	172	165	154	141	121	95,5	63,1	
6SDX 13/22	9.2	12.5		247	239	231	223	213	200	182	157	124	81,7	
6SDX 13/26	11	15		292	282	273	264	252	236	215	186	146	96,6	
6SDX 13/32	15	20		359	347	335	325	310	291	265	229	180	119	
6SDX 13/36	15	20		404	390	377	365	349	327	298	257	202	134	
6SDX 13/42	18.5	25		471	455	440	426	407	382	348	300	236	156	

DN	L	6SDX
	mm	kg
Rp 2" 1/2	446	13
	596	16.5
	716	19.5
	866	23
	986	26
	1166	30.5
	1286	33.5
	1466	38

P2 Rated motor power output

(...) FK motor rated power output

H Total head in m

Tolerances according to ISO 9906, annex A

# 6SDX 18

Submersible pumps for deep wells of 6"

## Characteristic curves, performance $n \approx 2900$ rpm, dimensions and weights

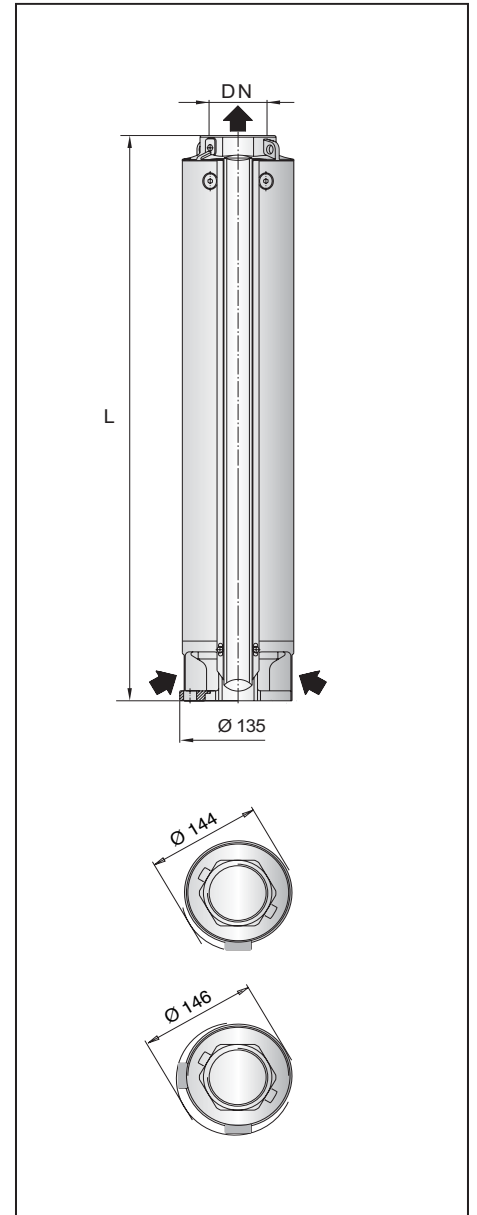
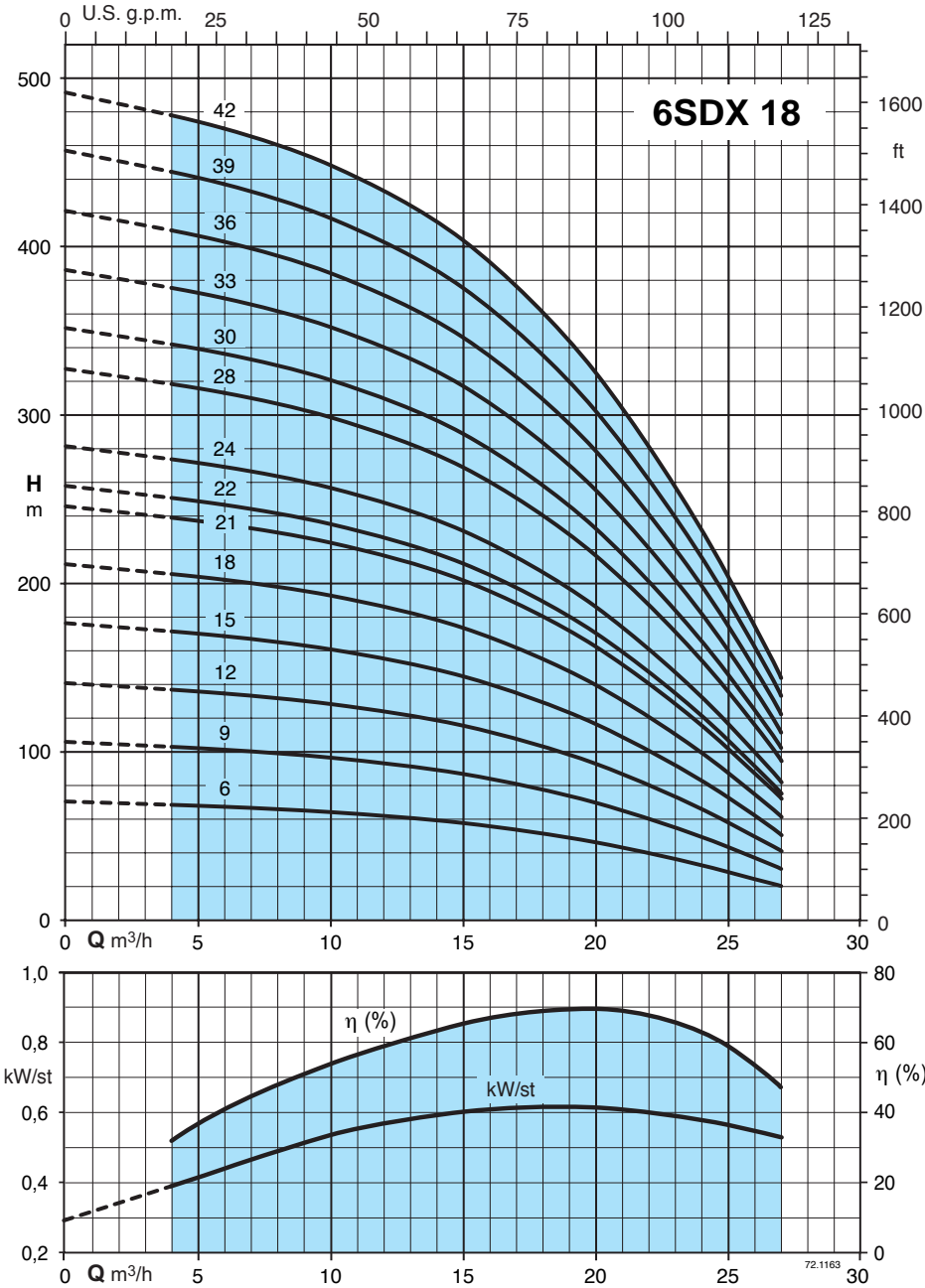

3 ~	P <sub>2</sub>		Q	n ≈ 2900 1/min										
	kW	HP		m <sup>3</sup> /h	0	4	6	9	12	15	18	21	24	27
				l/min	0	66,6	100	150	200	250	300	350	400	450
6SDX 18/6	4	5.5	H m	70,1	68,3	67,1	64,9	61,9	57,6	51,5	43,3	32,9	20,5	
6SDX 18/9	5.5	7.5		105	102	101	97,3	92,8	86,4	77,3	64,9	49,4	30,8	
6SDX 18/12	7.5	10		140	137	134	130	124	115	103	86,6	65,9	41	
6SDX 18/15	9.2	12.5		175	171	168	162	155	144	129	108	82,3	51,3	
6SDX 18/18	11	15		210	205	201	195	186	173	155	130	98,8	61,5	
6SDX 18/21	13 (15)	17,5 (20)		245	239	235	227	217	202	180	152	115	71,8	
6SDX 18/22	15	20		257	250	246	238	227	211	189	159	121	75,2	
6SDX 18/24	15	20		280	273	269	259	247	230	206	173	132	82	
6SDX 18/28	18.5	25		327	319	313	303	289	269	240	202	154	95,7	
6SDX 18/30	18.5	25		350	341	336	324	309	288	258	216	165	103	
6SDX 18/33	22	30		385	376	369	357	340	317	283	238	181	113	
6SDX 18/36	22	30		420	410	403	389	371	345	309	260	198	123	
6SDX 18/39	26 (30)	35 (40)		455	444	436	422	402	374	335	281	214	133	
6SDX 18/42	26 (30)	35 (40)		491	478	470	454	433	403	361	303	231	144	

DN	L	6SDX
	mm	kg
Rp 2" 1/2	431	12
	543.5	14.5
	656	16.5
	768.5	19
	881	21.5
	993.5	24
	1031	25
	1106	26.5
	1256	30
	1331	31.5
	1443.5	34
	1556	36.5
1668	39	
1853	42	

P<sub>2</sub> Rated motor power output

(...) FK motor rated power output

H Total head in m

Tolerances according to ISO 9906, annex A

# 6SDX 27

Submersible pumps for deep wells of 6"

## Characteristic curves, performance $n \approx 2900$ rpm, dimensions and weights

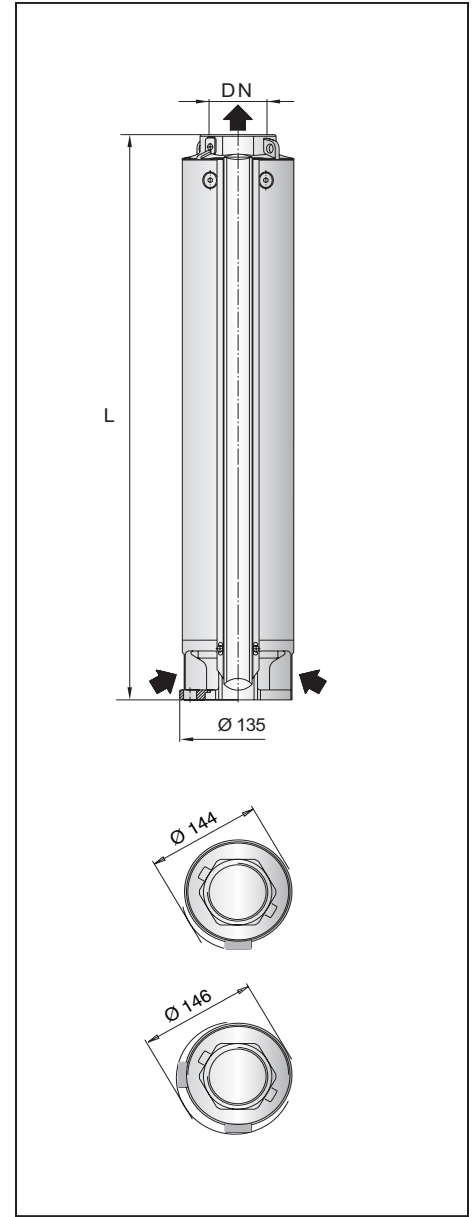
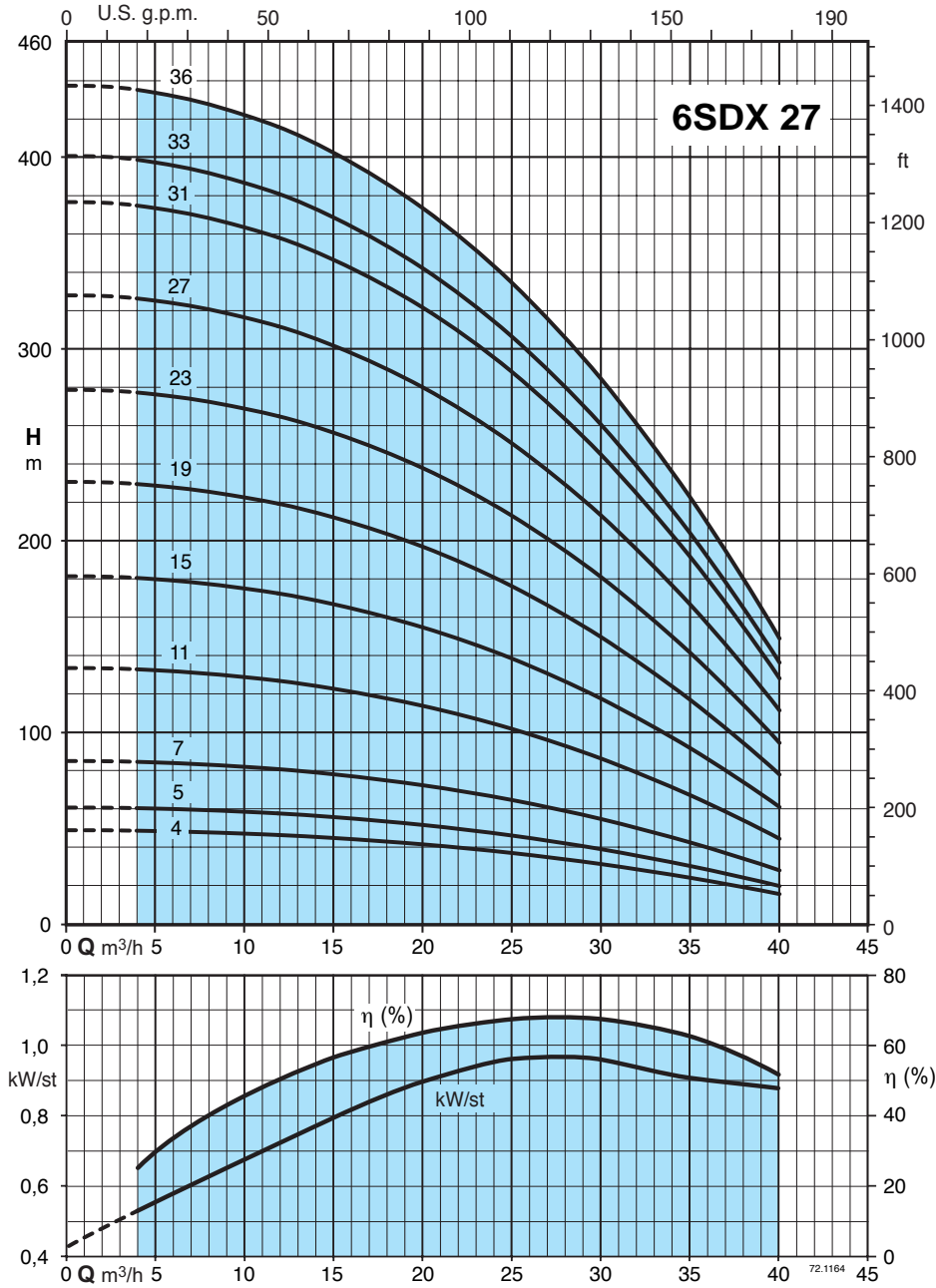

3 ~	P <sub>2</sub>		Q	n ≈ 2900 1/min											
				m³/h											
	kW	HP		0	4	8	12	16	20	24	28	32	36	40	
6SDX 27/4	4	5.5	48,4	48,2	48	46,4	43,8	41	38,1	33,4	28	22,8	16		
6SDX 27/5	5.5	7.5	60,5	60,2	60	58	54,7	51,2	47,6	41,8	35	28,5	20		
6SDX 27/7	7.5	10	84,7	84,3	84	81,2	76,6	71,7	66,6	58,5	49	39,9	28		
6SDX 27/11	11	15	134	133	131	127	121	114	105	93,2	79,7	63,9	45,8		
6SDX 27/15	15	20	183	181	178	173	165	156	143	127	109	87,1	62,5		
6SDX 27/19	18.5	25	231	230	226	219	209	197	181	161	138	110	79,2		
6SDX 27/23	22	30	280	278	273	265	253	239	219	195	167	134	95,8		
6SDX 27/27	26 (30)	35 (40)	329	326	321	311	297	281	257	229	196	157	113		
6SDX 27/31	30	40	377	375	369	357	341	322	295	263	225	180	129		
6SDX 27/33	(37)	(50)	402	399	392	380	363	343	314	280	239	192	138		
6SDX 27/36	(37)	(50)	438	435	428	415	397	374	343	305	261	209	150		

DN	L	6SDX
	mm	kg
Rp 3"	412	11.5
	458.5	12.5
	551.5	14.5
	737.5	18.5
	923.5	22.5
	1109.5	26
	1295.5	30
	1481.5	34
	1667.5	38
	1760	40
1899.5	43	

P<sub>2</sub> Rated motor power output

(...) FK motor rated power output

H Total head in m

Tolerances according to ISO 9906, annex A

# 6SDX 45

Submersible pumps for deep wells of 6"

## Characteristic curves, performance $n \approx 2900$ rpm, dimensions and weights

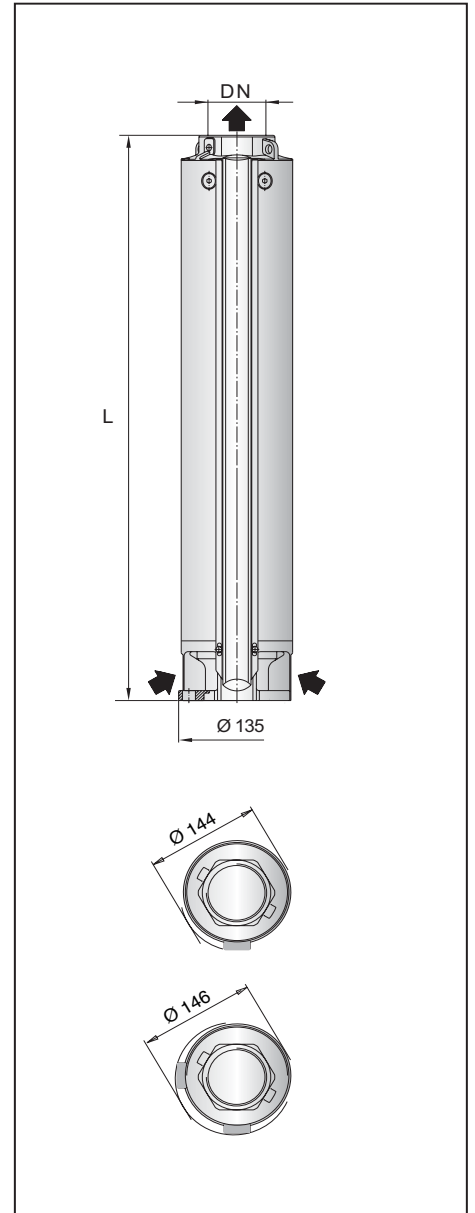
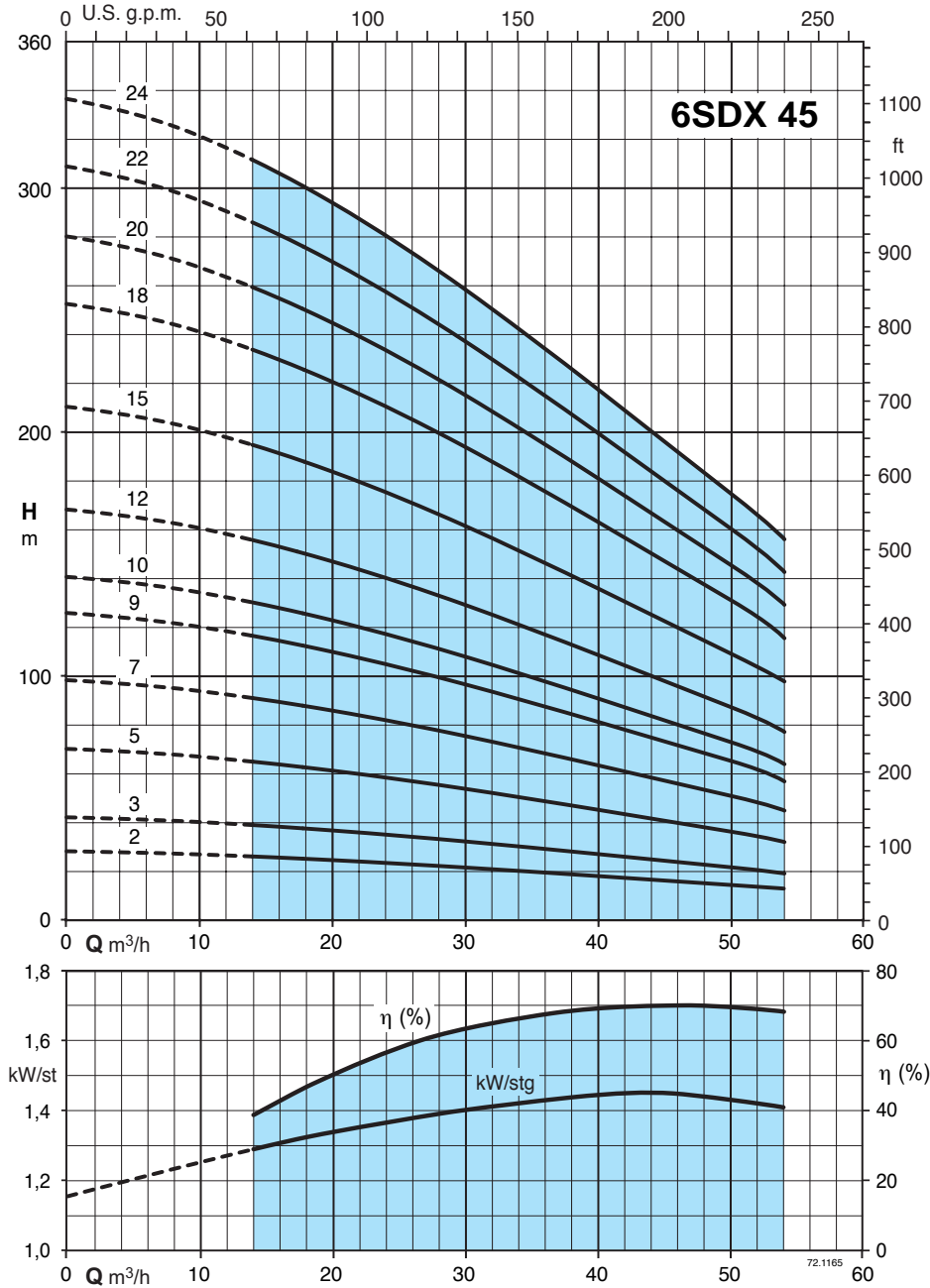

3 ~	P <sub>2</sub>		Q	n ≈ 2900 1/min											
	kW	HP		m³/h		l/min									
				0	14	18	22	26	30	34	38	42	46	50	54
6SDX 45/2	4	5.5	28	25,9	25	23,9	22,8	21,5	20,2	18,8	17,4	16	14,5	13	
6SDX 45/3	5.5	7.5	42	38,9	37,5	35,9	34,2	32,3	30,3	28,1	26,1	24,1	21,8	19,5	
6SDX 45/5	7.5	10	70	64,8	62,5	59,8	57	53,8	50,4	46,9	43,5	40,1	36,4	32,5	
6SDX 45/7	11	15	98	90,7	87,5	83,7	79,8	75,3	70,6	65,6	61	56,1	50,9	45,5	
6SDX 45/9	13 (15)	17,5 (20)	126	117	113	108	103	96,8	90,8	84,4	78,4	72,2	65,4	58,5	
6SDX 45/10	15	20	140	130	125	120	114	108	101	93,8	87,1	80,2	72,7	65	
6SDX 45/12	18.5	25	168	156	150	144	137	129	121	113	105	96,2	87,3	78	
6SDX 45/15	22	30	210	194	188	179	171	161	151	141	131	120	109	97,5	
6SDX 45/18	26 (30)	35 (40)	252	233	225	215	205	194	182	169	157	144	131	117	
6SDX 45/20	30	40	280	259	250	239	228	215	202	188	174	160	145	130	
6SDX 45/22	(37)	(50)	308	285	275	263	251	237	222	206	192	176	160	143	
6SDX 45/24	(37)	(50)	336	311	300	287	274	258	242	225	209	192	175	156	

DN	L	6SDX
	mm	kg
Rp 3"	365.5	11
	458.5	13.5
	644.5	18
	830.5	22.5
	1016.5	27
	1109.5	29.5
	1295.5	34
	1574.5	40.5
	1853.5	47.5
	2039.5	52
	2225.5	56.5
2411	61	

P<sub>2</sub> Rated motor power output

(...) FK motor rated power output

H Total head in m

Tolerances according to ISO 9906, annex A

# 6SDX 60

Submersible pumps for deep wells of 6"

## Characteristic curves, performance $n \approx 2900$ rpm, dimensions and weights

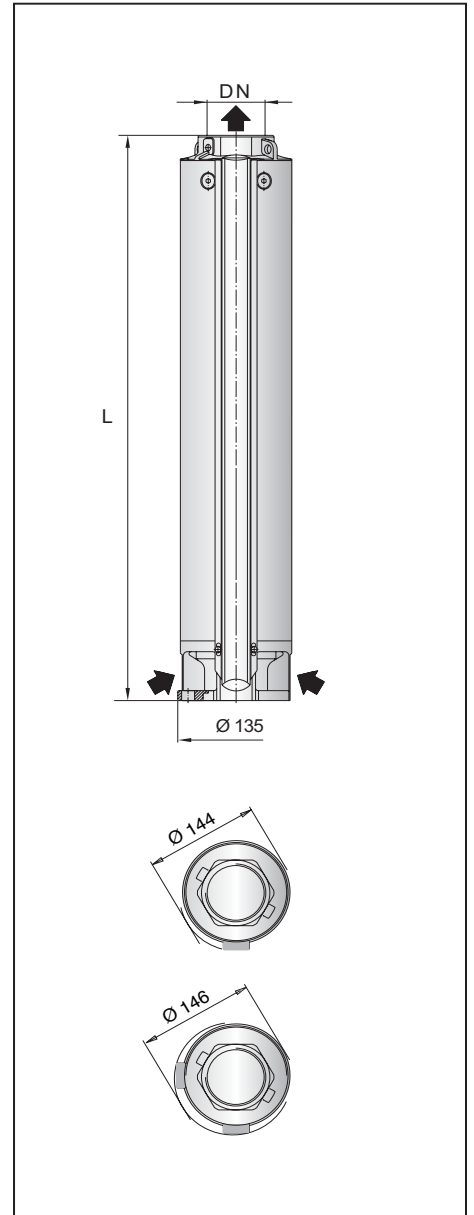
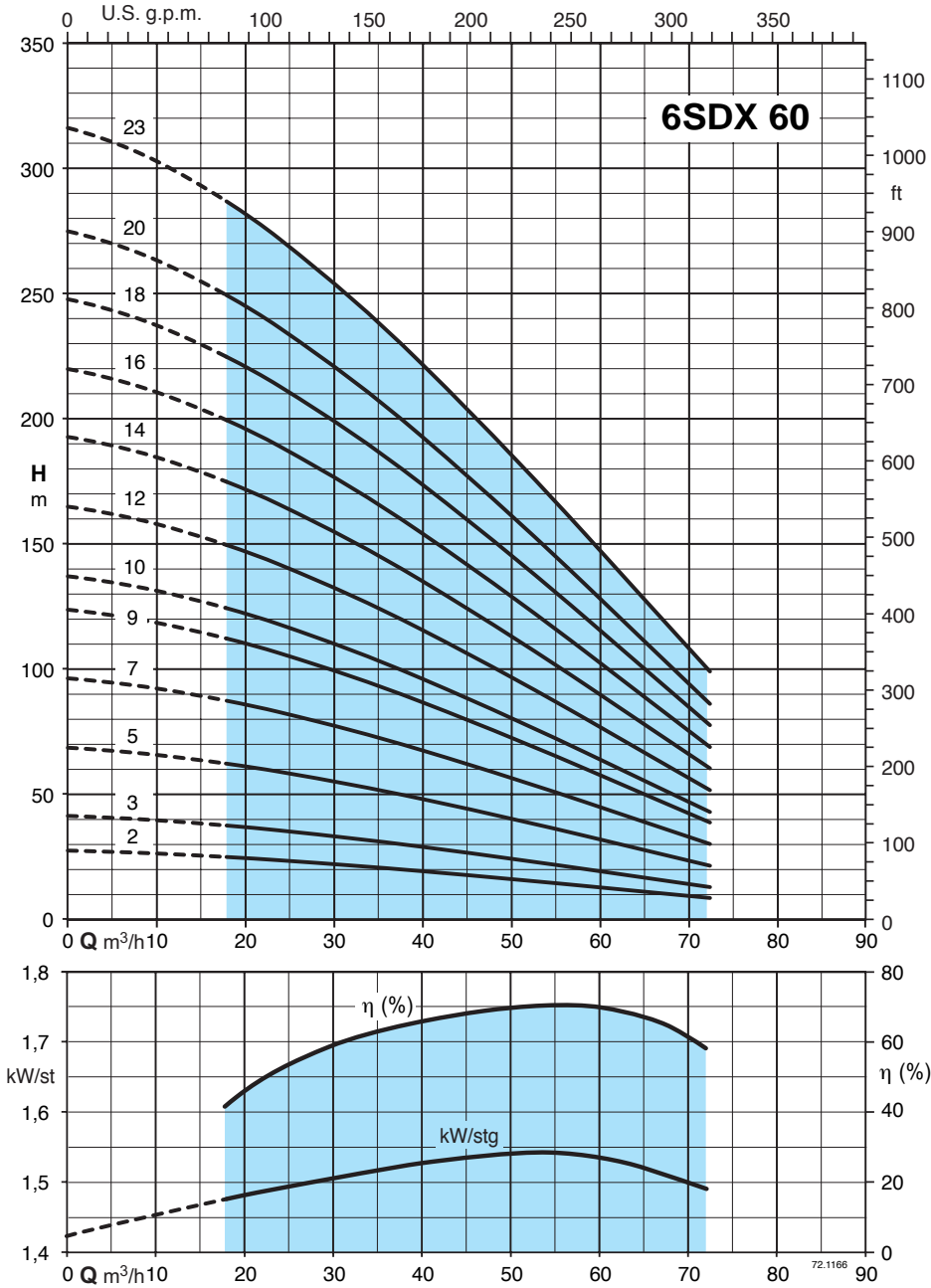

3 ~	P <sub>2</sub>		Q	$n \approx 2900$ 1/min											
	kW	HP		m <sup>3</sup> /h											
				0	18	24	30	36	42	48	54	60	66	72	
6SDX 60/2	4	5.5	H m	27,6	24,6	23,6	21,8	20,2	18,4	16,8	15	12,8	10,8	8,8	
6SDX 60/3	5.5	7.5		41,4	36,9	35,4	32,7	30,3	27,6	25,2	22,5	19,2	16,2	13,2	
6SDX 60/5	7.5	10		69	61,5	59	54,5	50,5	46	42	37,5	32	27	22	
6SDX 60/7	11	15		95,9	87	82,5	77,2	71,5	65,3	58,7	51,9	44,9	37,7	30,9	
6SDX 60/9	15	20		123	112	106	99,2	92	83,9	75,5	66,7	57,7	48,5	39,7	
6SDX 60/10	15	20		137	124	118	110	102	93,3	83,9	74,1	64,1	53,9	44,1	
6SDX 60/12	18.5	25		164	149	141	132	123	112	101	89	77	64,7	53	
6SDX 60/14	22	30		192	174	165	154	143	131	117	104	89,8	75,5	61,8	
6SDX 60/16	26 (30)	35 (40)		219	199	189	176	163	149	134	119	103	86,3	70,6	
6SDX 60/18	30	40		247	224	212	198	184	168	151	133	115	97	79,4	
6SDX 60/20	(37)	(50)		274	249	236	220	204	187	168	148	128	108	88,3	
6SDX 60/23	(37)	(50)		315	286	271	254	235	214	193	171	148	124	101	

DN	L	6SDX
	mm	kg
Rp 3"	365.5	11.5
	458.5	13.5
	644.5	18
	830.5	23
	1016.5	27.5
	1109.5	30
	1295.5	34.5
	1481.5	39
	1667.5	44
	1853.5	48.5
	2040	52
2318	60	

P<sub>2</sub> Rated motor power output

(...) FK motor rated power output

H Total head in m

Tolerances according to ISO 9906, annex A



# 8SDX 78

Submersible pumps for deep wells of 8"

## Characteristic curves, performance $n \approx 2900$ rpm, dimensions and weights

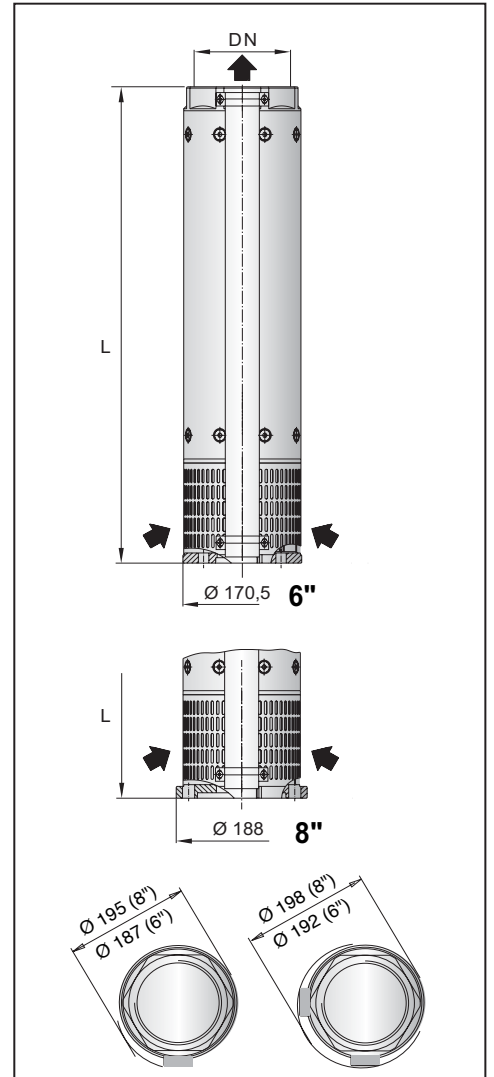
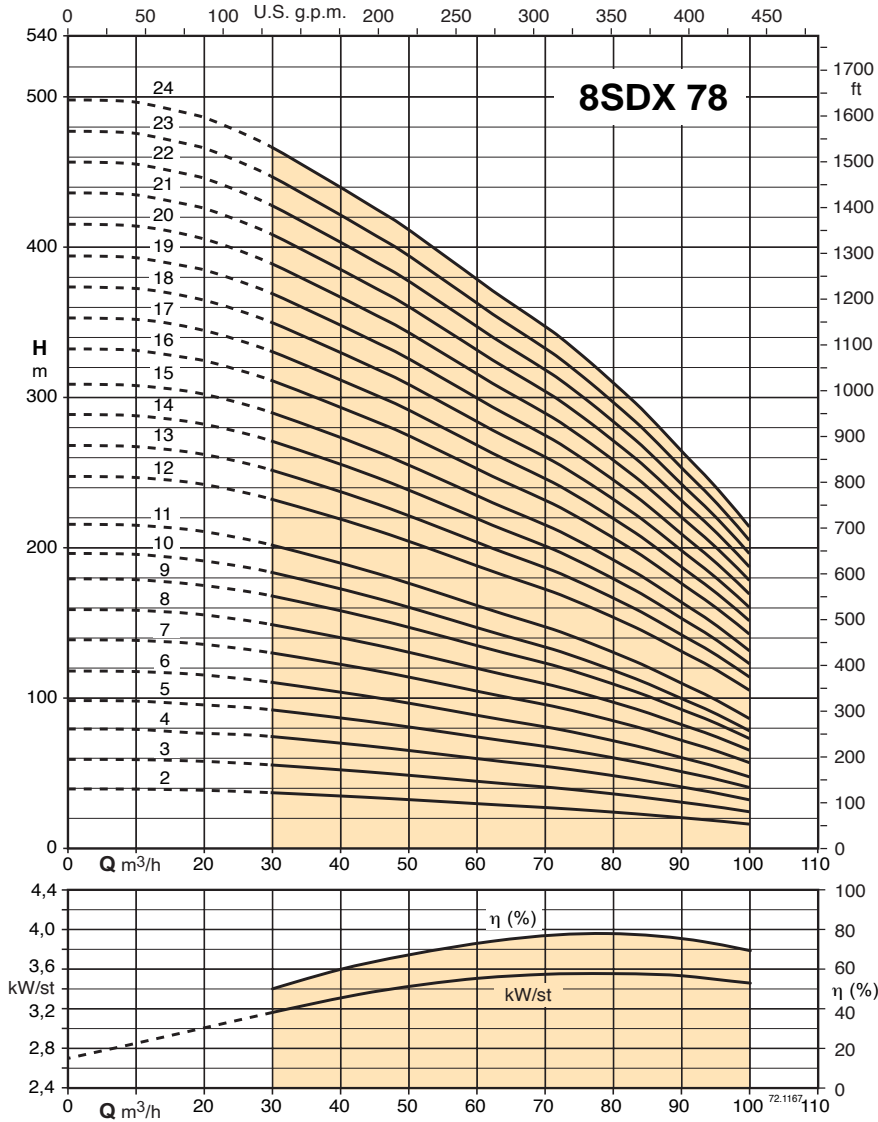

3 ~	P <sub>2</sub>		Q	n ≈ 2900 1/min																
	kW	HP		m³/h																
				0	30	40	50	60	70	80	90	100								
8SDX 78/2N	7,5	10	39,9	37,1	34,9	32,6	29,7	27,1	24,3	20,4	16,3									
8SDX 78/3N	11	15	59,8	55,7	52,3	48,9	44,6	40,7	36,4	30,6	24,4									
8SDX 78/4N	15	20	79,7	74,3	69,7	65,1	59,4	54,3	48,6	40,9	32,6									
8SDX 78/5N	18,5	25	99,6	92,9	87,1	81,4	74,3	67,9	60,7	51,1	40,7									
8SDX 78/6N	22	30	120	111	105	97,7	89,1	81,4	72,9	61,3	48,9									
8SDX 78/7N	26 (30)	35 (40)	140	130	122	114	104	95	85	71,5	57									
8SDX 78/8N	30	40	156	146	138	128	117	107	94,5	80	63,3									
8SDX 78/9N	30	40	176	164	155	144	132	120	106	90	71,2									
8SDX 78/10N	37	50	195	183	173	160	147	134	118	100	79,1									
8SDX 78/11N	37	50	215	201	190	176	162	147	130	110	87									
8SDX 78/12N	45	60	248	232	218	203	187	171	154	130	105									
8SDX 78/13N	51 (55)	70 (75)	268	251	237	220	203	185	166	141	114									
8SDX 78/14N	51 (55)	70 (75)	289	271	255	237	218	200	179	152	122									
8SDX 78/15N	55	75	310	290	273	254	234	214	192	163	131									
8SDX 78/16N	59 (75)	80 (100)	332	312	293	274	252	232	206	176	143									
8SDX 78/17N	66 (75)	90 (100)	353	332	311	292	268	247	219	187	152									
8SDX 78/18N	66 (75)	90 (100)	374	351	329	309	284	261	232	198	161									
8SDX 78/19N	75	100	394	371	348	326	299	276	245	209	170									
8SDX 78/20N	75	100	415	390	366	343	315	290	258	220	179									
8SDX 78/21N	75	100	436	409	385	361	331	304	271	231	187									
8SDX 78/22N	92	125	457	428	403	378	347	318	284	242	196									
8SDX 78/23N	92	125	478	448	422	395	363	333	297	253	205									
8SDX 78/24N	92	125	499	467	440	412	379	347	310	264	214									

DN	Motor		L	8SDX
	CS	FK		
mm	mm	mm	mm	kg
Rp 5"	145 6"	137 6"	644	31,5
			770	36,5
			896	41,5
			1022	46,5
			1148	51
			1274	56
	191 8"	196 8"	1400	61
			1526	66
			1652	71
			1778	76
			1909	82
			2035	87
196 8"	196 8"	2161	92	
		2287	97	
		2413	101,5	
		2539	106,5	
		2665	111,5	
		2791	116,5	
192 6"	192 6"	2917	121	
		3043	126	
192 6"	192 6"	3169	131	
		3295	136	
192 6"	192 6"	3421	141	

P<sub>2</sub> Rated motor power output

(...) FK motor rated power output

H Total head in m

Tolerances according to ISO 9906, annex A

# 8SDX 97

Submersible pumps for deep wells of 8"

## Characteristic curves, performance $n \approx 2900$ rpm, dimensions and weights

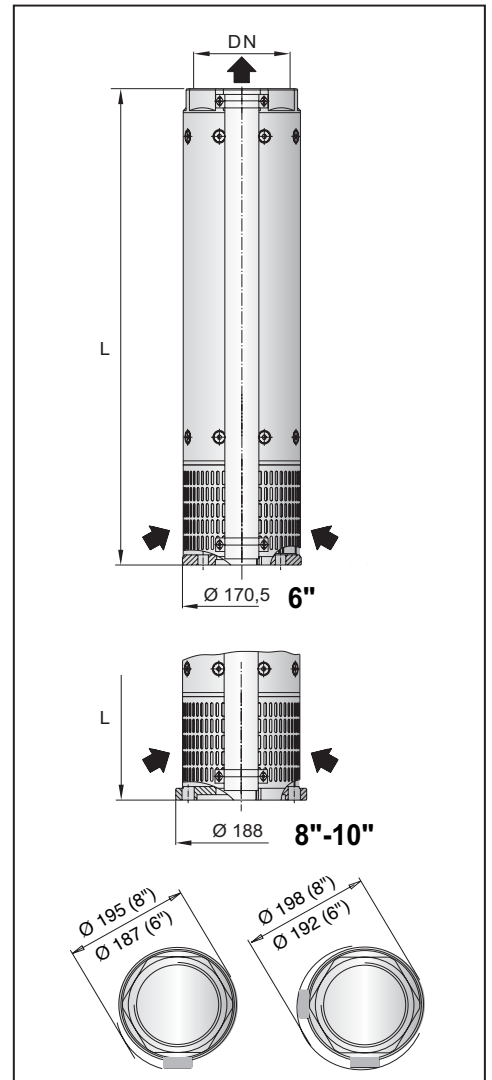
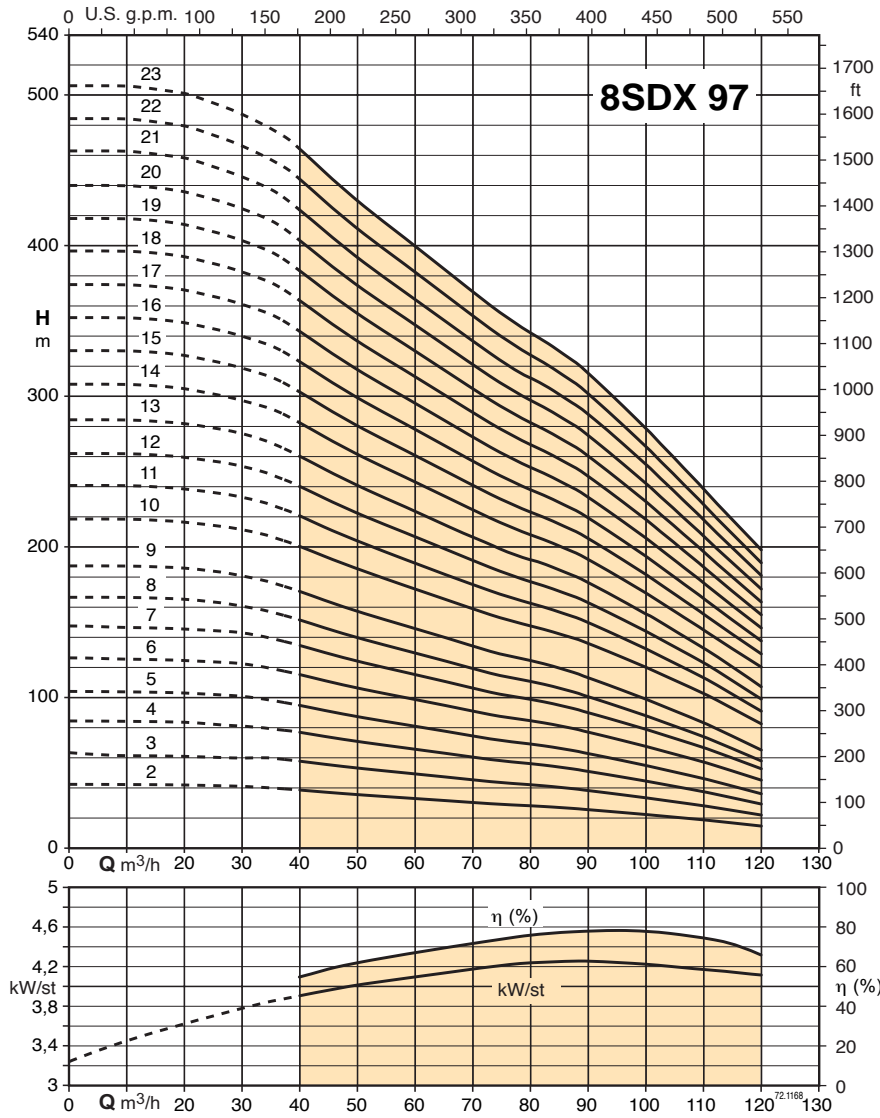

3 ~	P <sub>2</sub>		Q	n ≈ 2900 1/min														
	kW	HP		H														
				m														
8SDX 97/2N	9,2	12,5	41,2	38,6	35,2	32,2	29,8	27,8	24,8	21,8	18,6	14,8						
8SDX 97/3N	13 (15)	17,5 (20)	61,8	57,9	52,8	48,3	44,7	41,7	37,2	32,7	27,9	22,2						
8SDX 97/4N	18,5	25	82,4	77,2	70,4	64,4	59,6	55,6	49,6	43,6	37,2	29,6						
8SDX 97/5N	22	30	103	96,5	88	80,5	74,5	69,5	62	54,5	46,5	37						
8SDX 97/6N	26 (30)	35 (40)	125	113	105	96,7	89	82,7	75	66,3	55	44						
8SDX 97/7N	30	40	146	132	123	113	104	96,4	87,5	77,4	64,2	51,3						
8SDX 97/8N	37	50	167	151	140	129	119	110	100	88,4	73,3	58,7						
8SDX 97/9N	37	50	188	170	158	145	134	124	113	99,5	82,5	66						
8SDX 97/10N	45	60	219	200	185	172	158	147	135	119	102	83,1						
8SDX 97/11N	51 (55)	70 (75)	241	220	204	189	174	162	149	131	112	91,4						
8SDX 97/12N	51 (55)	70 (75)	263	240	222	206	190	176	162	143	122	99,7						
8SDX 97/13N	55	75	285	260	241	223	206	191	176	155	132	108						
8SDX 97/14N	59 (75)	80 (100)	309	281	262	242	224	208	191	169	144	120						
8SDX 97/15N	66 (75)	90 (100)	331	302	279	261	240	222	205	182	156	129						
8SDX 97/16N	75	100	353	322	298	278	256	237	219	194	166	138						
8SDX 97/17N	75	100	375	342	317	295	272	251	233	206	176	147						
8SDX 97/18N	92	125	397	362	335	313	288	266	246	218	187	155						
8SDX 97/19N	92	125	419	382	354	330	304	281	260	230	197	164						
8SDX 97/20N	92	125	440	403	374	348	322	298	274	244	209	173						
8SDX 97/21N	92	125	462	424	393	365	338	313	288	257	219	182						
8SDX 97/22N	110	150	484	444	411	383	354	328	301	269	230	190						
8SDX 97/23N	110	150	507	464	430	400	370	343	315	281	240	199						

DN	Motor		L	8SDX
	CS	FK		
Rp 5"	145 6"	137 6"	644	31,5
			770	36,5
			896	41,5
			1022	46
			1148	51
			1274	56
	191 8"	196 8"	1400	61
			1526	66
			1657	72
			1783	77
			1909	82
			2035	87
240 10"		2161	92	
		2287	97	
		2413	102	
		2539	106,5	
		2665	111,5	
		2791	116,5	
		2917	121	
		3043	126	
		3169	131	
		3295	136	

P<sub>2</sub> Rated motor power output

(...) FK motor rated power output

H Total head in m

Tolerances according to ISO 9906, annex A